



 Taubman
Cherry Creek

ARCHITECTURAL DESIGN CRITERIA

05.12.2023

TABLE OF CONTENTS

1.0 INTRODUCTION	02	2.0 ARCHITECTURAL DESIGN CRITERIA-		3.0 DETAILS & DIAGRAMS	
PHILOSOPHY	03	TEMPORARY BARRICADES	07	LEVEL PLANS	42-45
LEGAL STUFF	04	TYPICAL STORE FLOOR PLAN	08	LEVEL ELEVATIONS	
SUSTAINABILITY	05	DESIGN CONTROL AREA	08	AND SECTIONS	46-48
THE PROCESS	06	STOREFRONT DESIGN	09	TENANT SERVICE DOOR	49
		STOREFRONT MATERIALS	10-18		
		STOREFRONT SIGNAGE	19-23		
		STOREFRONT ELEVATION	24		
		STOREFRONT DIGITAL BRANDING	25-29	4.0 STORE SECURITY (ADDENDUM)	50-51
		CEILING TREATMENTS	30		
		CEILING HEIGHTS	31		
		LIGHTING	32-33		
		HEALTHY LIGHTING	33		
		FLOORING	34-38		
		WALL CONSTRUCTION	39		
		PUBLIC FACILITIES REQUIREMENTS	40		
		INTERIORS-GENERAL	41		
		COLUMNS	41		
		SOUND & OLFACTORY	41		

**STRUCTURAL, MECHANICAL, ELECTRICAL, PLUMBING, AND
FIRE PROTECTION CRITERIA LOCATED AT TENANTCOORDINATION.TAUBMAN.COM**

1.0 INTRODUCTION

CHERRY CREEK SHOPPING CENTER IS THE ROCKY MOUNTAIN REGION'S PREMIER SHOPPING ENVIRONMENT WITH OVER 160 SHOPS.

- ❑ The Center is located at the heart of the Denver metroplex and is easily accessible via six exits off I-25.
- ❑ Denver is a major tourist and convention destination attracting 17.4 million overnight visitors annually who spend \$5.6 billion.



1.0 INTRODUCTION

PHILOSOPHY

At The Taubman Company, our philosophy is to create retail centers that showcase exciting and successful stores. We encourage Tenants to be creative, innovative and develop an inviting and exciting store. The following guidelines have been created to outline our design philosophy, requirements, and recommendations when it comes to developing your space.

- ❑ **Good Design = Good Business:** Design focus is to be emphasized in the Tenant store and the Mall commons areas. Together, both areas influence the overall perception of the Mall environment and potentially your bottom line.
- ❑ **High Standards:** Consider these guidelines as a means to ensure that all Tenants and their respective consultants and contractors are designing and building to the same high standard to ensure the overall quality of the Mall environment.

“Good retail design is all about overcoming threshold resistance, bringing the customer into the store”

A. Alfred Taubman – Founder

- ❑ **Overcoming Threshold Resistance:** “The physical and psychological barriers that stand between your shopper and your merchandise... it’s the force that keeps your customers from opening your door and coming in over the threshold.”
- ❑ **Overcoming threshold resistance is one of the keys to being a successful retailer,** regardless of your approach to reaching your customer.

- ❑ **Omni-Channel Retail Experience:** most successful retailers rely on a multi-channel approach to marketing, selling, and serving customers with an Omni-channel retail approach. Omni-channel retail is a way that creates an integrated and cohesive customer experience no matter how or where a customer reaches out.
- ❑ **Brick & Mortar and the Omni-Channel Retail Experience:** As the Omni-channel Retail Industry continues to evolve, connecting people to your brand through the brick and mortar experience is more important than ever. Your store design offers customers an opportunity to see your brand in its physical manifestation and exposes people to unique opportunities to discover and connect to your brand.



1.0 INTRODUCTION

LEGAL STUFF

- ❑ **Rights:** We reserve the right to modify, add to, or delete from these guidelines at any time. Please understand that it's only because we are focused trying to create the best retail environment for all.
- ❑ **Disclaimer:** Please note, any and all drawings in this document are schematic in nature and are for reference purposes only.
- ❑ **Please note** It has been our intention to clarify any items that conflict however after you have read the complete Tenant manual document, please let the Tenant Coordinator know if you discover conflicting information that is not explained somewhere in the information.

PLEASE, PLEASE, PLEASE engage a highly qualified-experienced retail architect, designer, and contractor as early as possible in the lease process. Also, the sooner you complete the design and construction documents, the sooner the store will open.

- **Only use licensed professionals** in the preparation of architectural, design, mechanical, electrical, structural, etc. documents and construction work. Licensed professionals in these respective fields are required to be used.
- **Architectural site surveys** are to be completed by the Tenant. An on site review of the leased premises, surveying if required, is to be completed at the Tenants own expense. **We subscribe to the old saying... measure twice and cut once... for everyone's sake.**



1.0 INTRODUCTION

SUSTAINABILITY

- ❑ **Sustainable Design:** We encourage every retailer, architect, and contractor to create a environment using the latest sustainable design and construction practices.
- ❑ **We recommend the following Sustainable Guidelines for your space:**
 - **Establish a green construction policy** for renovations and tenant build-outs related to construction area, waste management, ventilation, worker protection and means & methods (See Facility Rules & Regulations for additional information).
 - **ENERGY STAR Products:** As you choose equipment and fixtures for your space, please consider installing ENERGY STAR® products. The ENERGY STAR label allows you to easily identify products that meet strict requirements for energy efficiency. You can search for ENERGY STAR products at <https://www.energystar.gov/products>. Discounts may be available for bulk purchases.

ENERGY STAR models of the following equipment are available: Computers, Copiers and Faxes, Data Storage, Enterprise Servers, Ice Makers, Mailing Machines, Monitors and Displays, Notebook Computers and Tablet PCs, Printers and Scanners, Refrigerators, Telephones, Televisions, Vending Machines, Water Coolers.
 - **Healthy, low-emitting materials for tenant build-outs:** Zero or low-VOC (50 grams per liter or less) drywall primer/sealer, paint, caulks, adhesives, sealants, and wood finishes, Formaldehyde-free composite wood products, including plywood, particleboard, and medium density fiberboard (MDF), Finish flooring that does not contain phthalate compounds, Workstations and furnishings that do not emit VOCs or formaldehyde, Chairs free of PBDE flame retardants.
- ❑ **Healthy, Low-Emitting Products:** We recommend using the following certification systems to identify healthy, low-emitting products:
 - U.S. EPA Safer Choice, C2C (Cradle to Cradle), SCS (Scientific Certification Systems), Green Seal, BIFMA Product Safety and Performance Standards and Guidelines (Business and Institutional Furniture Manufacturer’s Association), GREENGUARD Label, CRI Green Label and Green Label Plus (Carpet and Rug Institute), International Living Future Institute’s Declare Database.
- ❑ **Install high-efficiency plumbing fixtures for tenant build-outs: (see MEP Criteria for additional information).**
- ❑ **Healthy lighting for tenant build-outs: (See Lighting Section of this Criteria for additional information).**



1.0 INTRODUCTION

THE PROCESS



2.0 ARCHITECTURAL DESIGN CRITERIA

TEMPORARY BARRICADES

- ❑ **Temporary storefront barricades are required during construction to create a containment area for Tenant construction activity.**
- ❑ **Refer to the local Center management team and the Center rules & regulations** located at <http://Tenantcoordination.taubman.com> for barricade requirements including, but not limited to, installation and removal, relocation, dust containment, entry conditions, etc.
- ❑ **Full Color Graphics:** Prior to printing and installation, the Tenant shall submit full color graphic content to the facility director at the Center for approval. Only Landlord approved signage will be permitted on the barricade. All graphics must be installed by Boston Barricade.
- ❑ **Promote your brand** using your barricade graphics during store construction. Applying graphics to the barricade enhances a retailers brand image. Graphics should support and bolster your brand image with logos, tag lines, imagery, and colors.

TYPICAL BARRICADE SECTION

SCALE: NTS

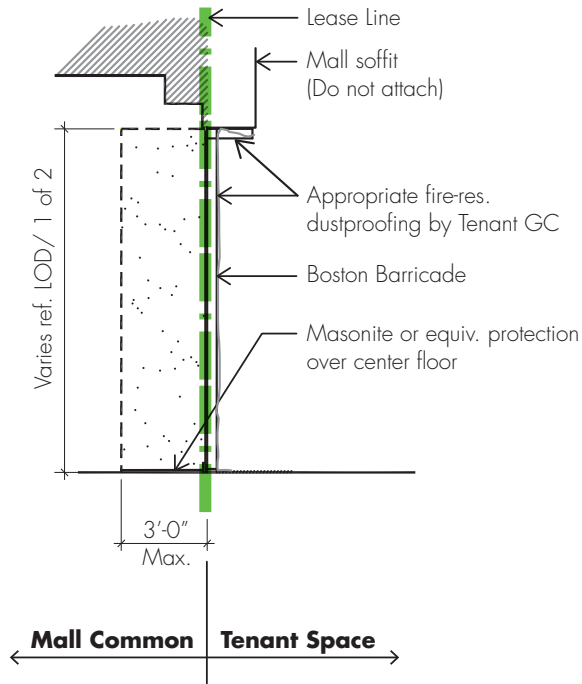

✓ ACCEPTABLE



✗ PROHIBITED



✓ ACCEPTABLE



✗ PROHIBITED

2.0 ARCHITECTURAL DESIGN CRITERIA

TYPICAL STORE FLOOR PLAN

DESIGN CONTROL AREA

- Design Control Area (DCA): Focus, Focus, Focus on the DCA.** The Design Control Area is the area of the store extending from the storefront lease line into the store approximately +/- ten feet (10'-0") across the entire width of the store. As the design in this zone is so critical to the overall appearance of the store, we will focus on this area for the majority of our design comments.
- Emphasize your brand** but consider the context within which you are designing, the terms of the lease and the following Criteria when designing your space. We want you to express your individuality and brand but we ask that the factors above are kept top of mind when designing and building.

- Floor plan: Plan, Plan, Plan...** A well thought out plan allows Tenants to explore creative design options and store layouts that emphasize your brand and encourage customers to browse and buy.
- Creating a fully integrated design** includes coordinating the building specs, customer traffic flow, product placement, finishes, materials, lighting, color, display windows, signage, flooring, transitions, etc. Using the highest quality materials in all instances.

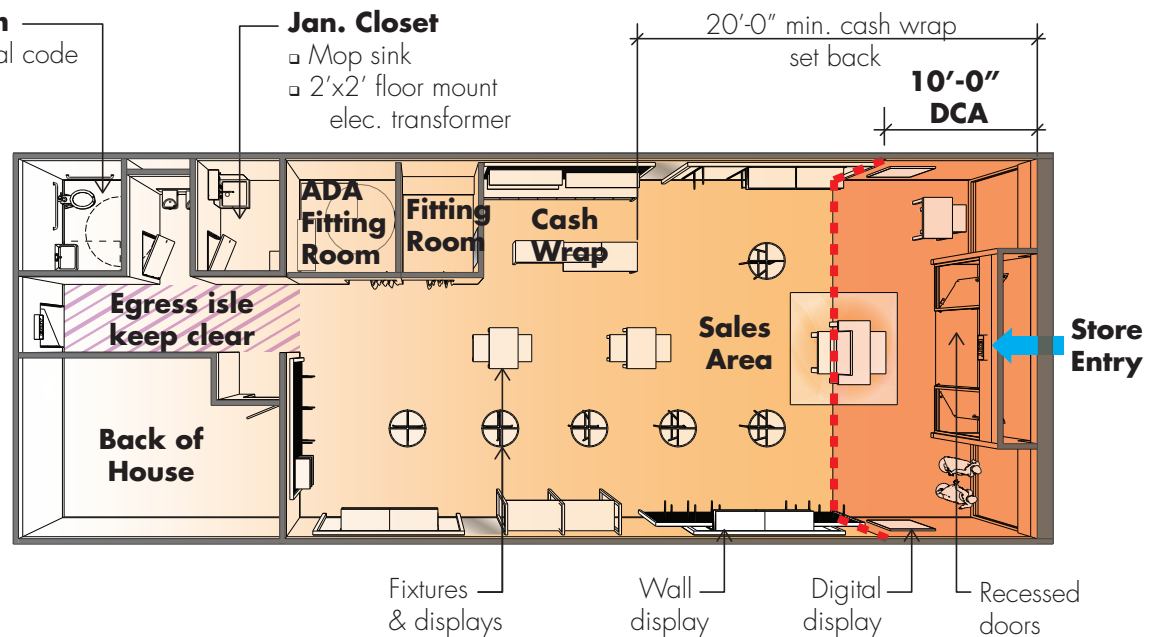
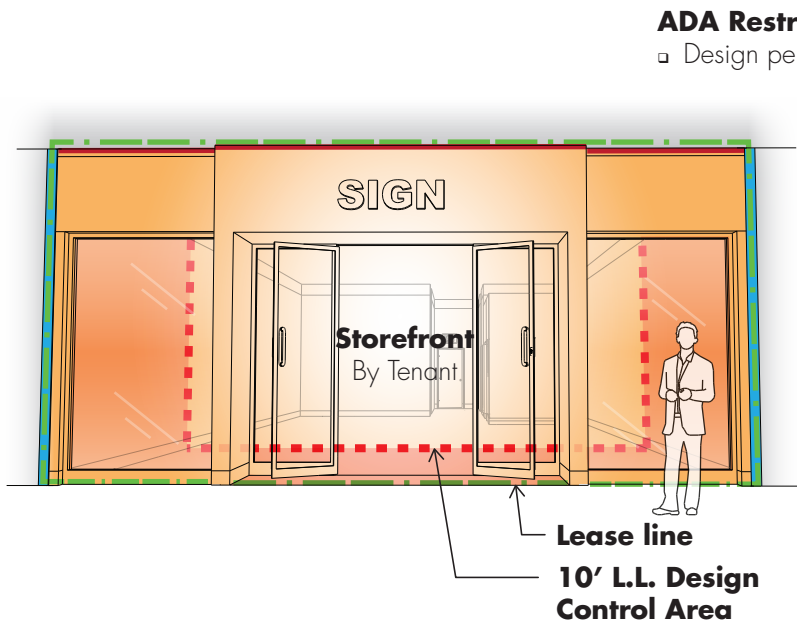

DCA ELEVATION

SCALE: NTS (TENANT SPACES WILL VARY)

TYPICAL MERCHANDISE PLAN

SCALE: NTS (TENANT SPACES WILL VARY)

2.0 ARCHITECTURAL DESIGN CRITERIA

STOREFRONT DESIGN

You only get one chance to make a first impression...

So give the customer a reason to stop at your store by creating an exciting storefront design that helps tell the story of your brand.



2.0 ARCHITECTURAL DESIGN CRITERIA

MATERIALS & FINISHES

- ❑ **Material Samples:** Tenant must provide an 11"x17" material sample board with their plan submittal (labels must be consistent with the plan submittal legend.)
- **Photos and Renderings:** In addition, we suggest the Tenant provide photos of finishes from a comparable existing store or renderings for the proposed storefront design with their plan submittal.
- ❑ **Tenant finishes** within the DCA shall be **durable** such as glass, tile, metal, stone, terrazzo, plaster, hardwood, or similar materials approved by the Landlord.
- ❑ **Detailing or joinery of differing materials** is very important. A carefully defined edge must be established between different horizontal and vertical Tenant materials and surfaces as well as between the Tenant and Landlord finishes.



2.0 ARCHITECTURAL DESIGN CRITERIA

STOREFRONT GLAZING, ENTRANCES, AND CLOSURES

- ❑ **Glazing Design:** Full height-but glass is preferable to framed windows. Refer to the local building codes when sizing full height glass members.
 - Glazing designs that employ articulated moldings, muntins, or beveled glass. Leaded or stained glass also may be appropriate but may not be simulated, applied, or reproduced in acrylic, or plexiglass.
 - **Storefront glass** shall be clear, safety plate or tempered float glass. No tinted glass will be allowed.
 - **Exposed edges** should be polished. Silicone shall not be used unless required by local code.
 - **Clips or brackets** when required, should complement the design and not detract from the beauty of a clean and uninterrupted view of the store and merchandise.
- ❑ **Storefront Projections:** Construction shall not project beyond the storefront lease line, including finishes and door swings.
- ❑ **Storefront base** must be hard surface (tile or metal, typical) that can withstand the regular wear and tear of cleaning equipment and pedestrian traffic.
- ❑ **Swinging doors** may be left open and in a locked position as long as they don't extend past the lease line and are integrated into the overall storefront design... not an afterthought.
- ❑ **Sliding Doors and Overhead Grills:** Sliding doors and overhead grills shall be concealed in an side storage pocket or overhead during shopping center hours.
- ❑ **Security Devices:** Please refer to page 50-51, Store Security for full information.



2.0 ARCHITECTURAL DESIGN CRITERIA

TRANSITIONS-TRANSITIONS/DEMISING CONDITIONS

- **Neutral Piers-Existing Mall:** Neutral piers are existing. Any new neutral piers will be built by the Tenant's contractor, at the Tenant's expense, per drawing supplied by Landlord. (Refer to "Details and Diagrams" section of Criteria)

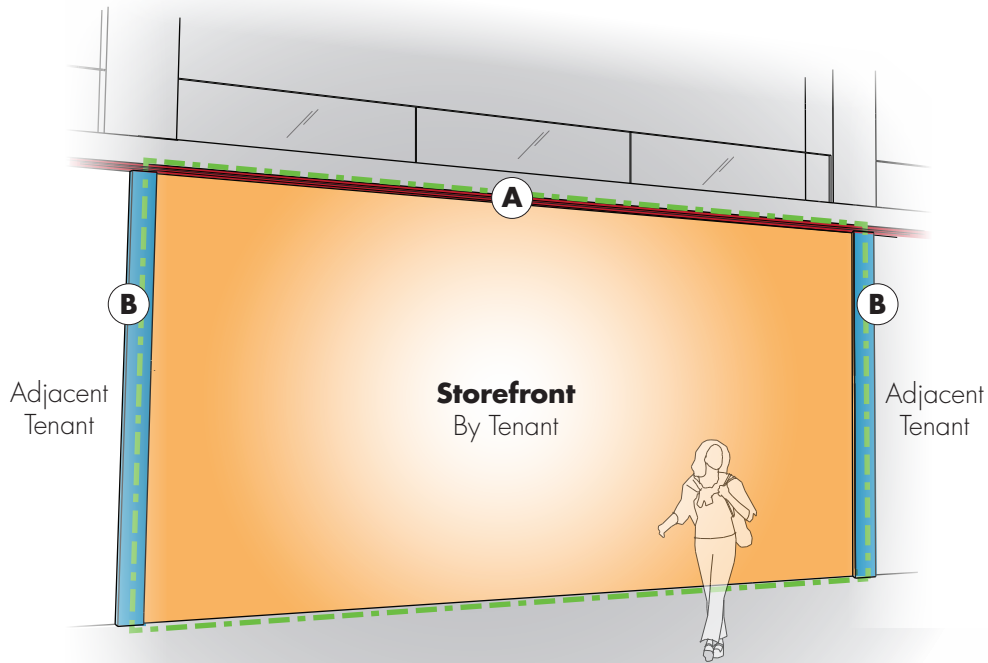

TYPICAL U-CHANNEL ELEVATION
SCALE: NTS

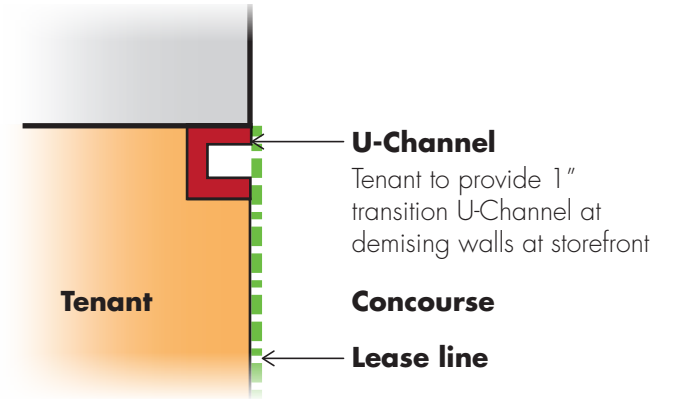

A OPTIONAL U-CHANNEL SECTION @ BULKHEAD
SCALE: NTS

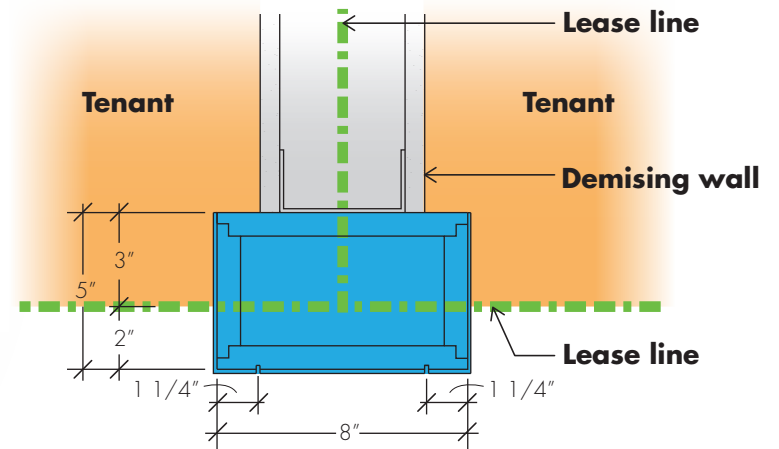

B TYPICAL NEUTRAL PIER SECTION @ DEMISING WALL
SCALE: NTS

2.0 ARCHITECTURAL DESIGN CRITERIA

STOREFRONT MATERIALS-STONE

- ❑ **Stone:** Stone, granite, marble, limestone, slate, and other natural stone materials may be used in storefront applications.



- ❑ **Stone** may be polished, unpolished, sandblasted, flamed, honed, split face, or carved. Careful craftsmanlike attention to detail is required at all connections and transitions to other materials.

- ❑ **Transition** between stone and adjacent materials must be defined by metal reveals.

- ❑ **Edge details** must prevent visible unfinished edges. Exposed edges must be quirk mitered, chamfered, or polished to match adjacent surface finish.

- ❑ **Natural stone** must be protected against staining and discoloration by means of sealers.



2.0 ARCHITECTURAL DESIGN CRITERIA

STOREFRONT MATERIALS-METALS

❑ **Metals:** All storefront metal panels must meet Landlord requirements below.



- ❑ **Textured or brushed** stainless steel, galvanized, sandblasted, and etched metals are encouraged in creative applications.
- ❑ **Minimum 18 gauge** metal panels are required. Min 1/2" thick fire rated plywood substrate is required.
- ❑ **Fabrication** must be either heavy gauge material or thinner gauge material shop laminated to solid backing. In no case is oil canning (resulting from light reflection from an uneven or buckled surface). Scratches, warps, dents, occlusions, visible seams, or other imperfections are not permitted.
- ❑ **Sealants** on natural metals are required to prevent tarnishing and must be maintained by Tenant at Tenant's expense.

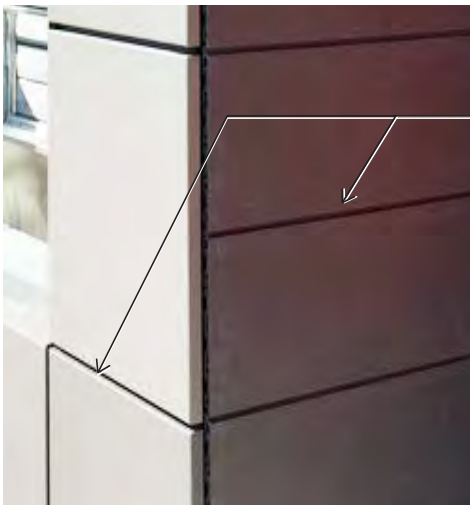

- ❑ **All joints and seams** must be even, straight and concealed when possible. Outside corners are to be mitered, continuous break shaped, bent, or hemmed. **Seams between metal panels must be identified on the storefront elevations.**
- ❑ **Reveals:** Metal panels will not be allowed to directly come into contact with adjacent panel. Reveals, turn in seams, welding, or similar must be specified and detailed out on the plans. **No visible fasteners permitted.**



2.0 ARCHITECTURAL DESIGN CRITERIA

STOREFRONT MATERIALS-WOOD

- ❑ **Wood:** Painted or stained wood may be used in many design applications, such as window frames, decorative trim, molding, and for solid areas, such as decorative bulkheads. In some cases it may be used for larger architectural elements, such as columns and entrances.



- ❑ **Painted wood** must have a shop quality enamel or clear finish.
- ❑ **Detailing & construction** to be executed in a high quality craftsmanlike manner.
- ❑ **All wood used in construction of storefront** must be kiln dried, mill quality hardwood, and must meet local flame spread requirements.

- ❑ **Extensive use** of natural wood finishes is discouraged. All stains and finishes must be Landlord approved.
- ❑ **Wood paneling** and plank construction is not acceptable unless presented in a highly imaginative concept and approved by the Landlord.



2.0 ARCHITECTURAL DESIGN CRITERIA

STOREFRONT MATERIALS-TILE

- ❑ **Tile** may be used in diverse applications. Its use is encouraged to introduce light, decorative texture or graphic quality to a storefront.



- ❑ **Mosaic:** Small and intricate mosaic tile patterns may be utilized for detail and accent only.

- ❑ **Porcelain, ceramic, or glass tiles** in glazed or natural finishes may be used as accents and in limited field applications. Patterns used over large areas are expected to have a sophisticated well executed design concept.

- ❑ **Porcelain tiles** are known to be denser and less porous than ceramic tiles. Porcelain tiles are highly resistant against chipping and scratching.



- ❑ **Grout color** should match the background color of the tile so as not to emphasize a grid pattern.

- ❑ **Corner Details:** All tile must be carefully detailed at outside corners with bull nose edges or special corner trims. Lapped or butt joints are not permitted.



2.0 ARCHITECTURAL DESIGN CRITERIA

STOREFRONT MATERIALS-PAINTED SURFACES

- ❑ **Painted Surfaces:** Any paint applied to the materials in the storefront must be specified and is subject to Landlord review and approval.



- ❑ **Painted metal** shall have a factory applied finish of baked enamel or powder coat treatment.
- ❑ **Painted wood** surfaces must be properly prepared and sealed prior to the application of a high grade enamel or low VOC Epoxy type finish.
- ❑ **Painted gypsum** wall board will be allowed only within the interior of the storefront, not on the exterior storefront.
- ❑ **Required MDF finish process:** 1 coat primer, 2 coats finish (sprayed and sanded between each step). Min. thickness for MDF is 3/4" on storefronts.

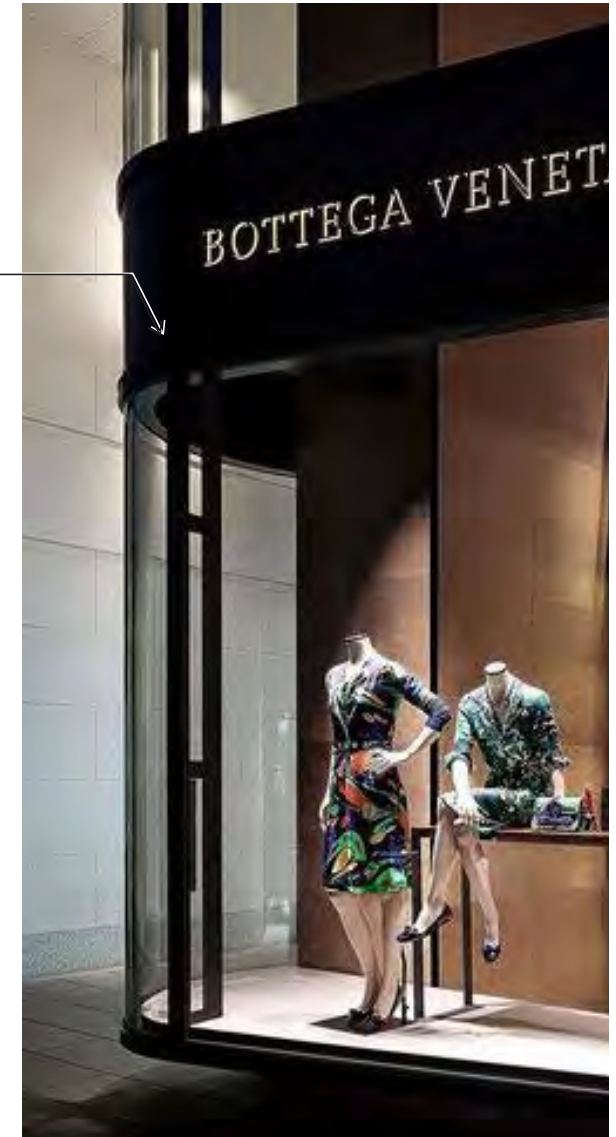
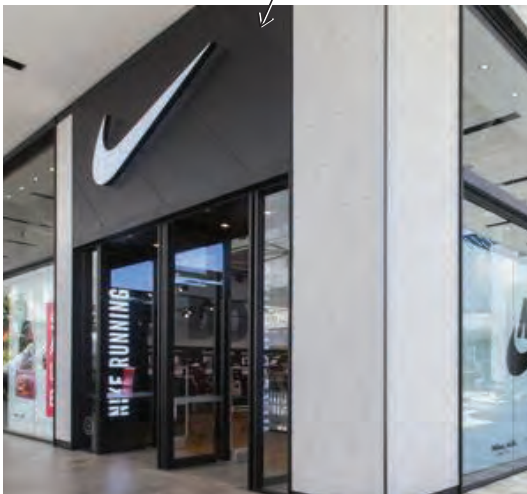

2.0 ARCHITECTURAL DESIGN CRITERIA

STOREFRONT MATERIALS-MISC.

- ❑ **Precast Stone and Concrete:** Many precast stone and concrete products are currently available that may be acceptable for storefront applications. The use of these materials is at the discretion of the Landlord.
- ❑ **Plaster:** Plaster, cement plaster (stucco), and venetian plaster finishes may be considered for limited storefront applications. Plaster or stucco finishes should be used in combination with other high quality materials such as stone or metal and not be the primary storefront material.
- ❑ **Finish Textures:** Should be a light dash, sand, or smooth finish.
- ❑ **Faux Finishes:** Faux finishes may be used at the Landlord's discretion. Actual samples of the faux finish must be submitted to the Landlord.
 - Photographs of previous examples are helpful but may not be substituted for an actual sample.
 - Faux finishes must be executed by a commercial artisan specializing in that medium.



PROHIBITED MATERIALS

The following is a list of prohibited materials. In rare instances, special consideration may be given for the use of a prohibited material if its application is highly original, creative and essential to the theme or design concept of the storefront. Exceptions will be determined by the Landlord during design review:

- ✗ Plastic laminates
- ✗ Glossy or large expanses of acrylic or plexiglas
- ✗ Pegboard
- ✗ Mirror
- ✗ Highly polished or plated metals except as trim
- ✗ Reflective glass
- ✗ Distressed woods such as pecky cedar, rough sawn lumber, and softwoods.
- ✗ Anodized aluminum
- ✗ Vinyl, fabric, or paper wall coverings
- ✗ Plywood or particle board
- ✗ Sheet or modular vinyl
- ✗ Luminous ceilings including “egg crate”
- ✗ Vinyl awnings
- ✗ Shingles, shakes, and rustic siding

2.0 ARCHITECTURAL DESIGN CRITERIA

STOREFRONT SIGNAGE-INTERIOR

- ❑ **Number of Signs:** Tenant shall identify the premises by installing **(1) one primary identification sign** on the storefront elevation. Second sign at corner conditions may be permitted per Landlords approval.
- ❑ **Store Name/Trade Name:** Store identification signs shall be limited to the store name (D.B.A.). Wording of signs shall not include the product sold except as part of Tenant's trade name. The use of a crest, shield, logo, or other established corporate insignia which has been customarily displayed or associated with the store name may be approved on an individual basis by the landlord at Landlord's sole discretion.
- ❑ **Height:** The average height of sign letters or components **shall be twelve inches (12" in.) average and sixteen (16" in.) max.**
- ❑ **Projection:** Signs shall not project beyond the storefront more than two inches (2" in.) if less than eight feet (8'-0" ft.) above finished floor line, nor more than four inches (4" in.) above eight feet (8'-0" ft.).
- ❑ **Limits:** The extreme outer limits of the sign letters and components shall fall within a rectangular area that can be defined as follows:
 - The sides shall not fall closer than twenty four inches (24" in.) to the side lease lines of the premises.
 - The top side of which shall fall no closer than twelve inches (12" in.) to the soffit of the Mall fascia.
- ❑ **Fonts:** One font style with various heights, weights, and one color is strongly recommended in order to provide an economical and timely sign installation.
- ❑ **Review and Approval: All signage, identification, and graphics are subject to the approval of the Landlord.** The Landlord maintains all authority to reject any sign or sign component, whether specifically addressed in this manual or not.
 - All signage shall be submitted to Landlord for approval with scaled shop drawings.
 - All signs and sign installation shall comply with all local building and electrical codes.



2.0 ARCHITECTURAL DESIGN CRITERIA-EXISTING & EXPANSION

STOREFRONT SIGNAGE-INTERIOR

- ❑ **Service Door Sign-Interior:** A uniform store identification sign shall be installed by Tenant per Landlord's specifications. Tenant shall not post additional signs in service areas. Letters are to be three inch (3" in.) high in black vinyl applied directly to the outside face of the Tenant's door. Wording shall be limited to Tenant's name and space number only.

STOREFRONT SIGNAGE-EXTERIOR

In addition to the criteria specified in the interior signage section, Tenants with exterior entrance signage shall also comply with the following.

- ❑ **Exterior Sign Height:** The maximum height of sign letters or components shall not exceed twenty inches (24" in.) but size is subject to Landlord approval and may be required to be smaller.
- ❑ **Sign Outer Limits- Exterior:** The extreme outer limits of the sign letters and components shall fall within a rectangular area that can be defined as follows:
 - The sides shall not fall closer than twenty-four inches (24" in.) to the side lease lines of the premises.
 - The top side of which shall fall no closer than twelve inches (12" in.) to the soffit of the mall fascia.
- ❑ **Awnings and Canopies** will be allowed for select exterior curbside Tenant elevations only. All designs shall be submitted for approval by Landlord.
 - Illumination of awning shall be wash-lit from above awning by approved fixture. Fixture counts and placement shall be indicated on submittal drawings, as well as foot-candle.

- ❑ **Service Door Sign-Exterior:** Rear door shall have store suite address number only posted at six feet (6'-0" in.) above curb, white four inch (4" in) vinyl.
- ❑ **Postal Service Sign:** (Exterior Curbside Storefronts Only): Street address identification (street number only) for postal delivery is required and must be placed in the lowest left hand corner of the storefront glazing. Numbers to be six inch (6" in.) white vinyl mounted to the inside face of the glass.



2.0 ARCHITECTURAL DESIGN CRITERIA

SPECIFIC SIGN GUIDELINES



Pin mounted



Dimensional



Applied to glass

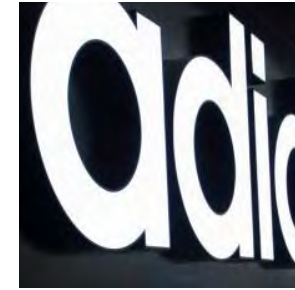

Internal illumination



Edge lit



Back lit



Dimensional



Pin mounted

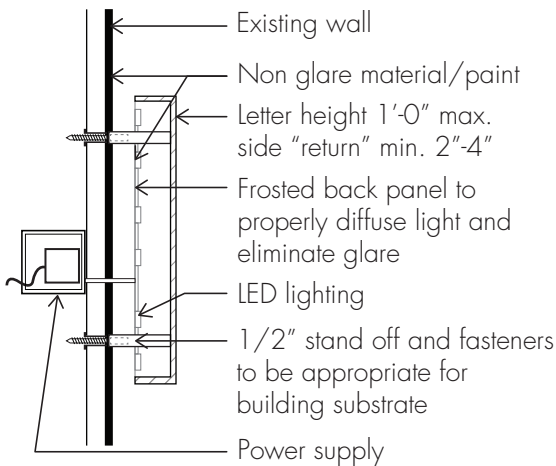

Illuminated pin mount

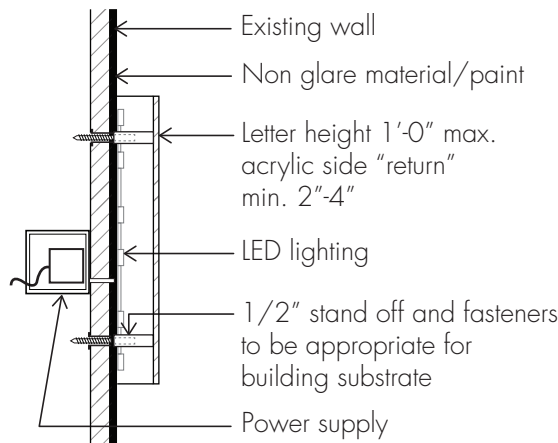

Illuminated channel

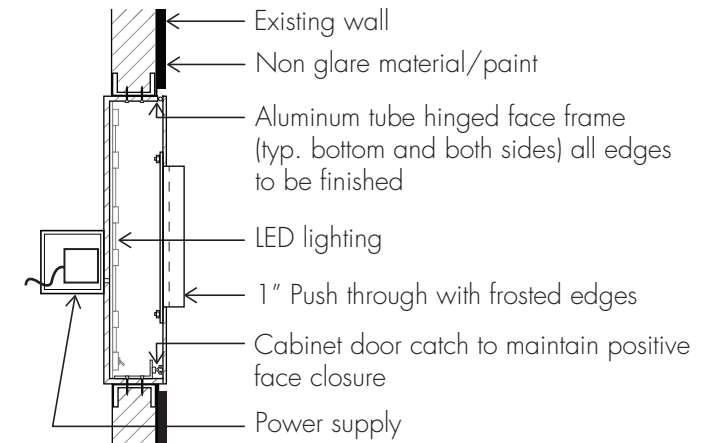

Push through

2.0 ARCHITECTURAL DESIGN CRITERIA

STOREFRONT SIGNAGE

PROHIBITED SIGN TYPES

- ✘ Signs with exposed fasteners, vents, or weep holes. **Exterior signs may have weep holes but they must be baffled.**
- ✘ Signs with exposed neon or other lamps and signs using flashing lights.
- ✘ Sign manufacturer's name, stamps, decals, or registered trade marks.
- ✘ Signs with exposed raceways, ballast boxes, or transformers.
- ✘ Signs with painted letters
- ✘ Signs employing luminous, vacuum formed plastic letters.
- ✘ Signs of exposed box or cabinet type design that employ transparent, translucent, or luminous plastic background panels.
- ✘ Shadow box type signs
- ✘ Signs employing unedged or uncapped plastic letters with no returns.
- ✘ Paper, plastic, or cardboard signs. In addition, stickers or decals of any kind are not permitted on the storefront glass or in entry area, unless approved by Landlord.
- ✘ No sign, advertisement, notice or other temporary lettering shall be exhibited, inscribed, painted, or affixed on any part of the storefront(s) except store identification signs.

POSSIBLE SIGN TYPES

- ✓ Signs with an orientation other than horizontal, that is, no vertical, perpendicular (blade signs), or diagonal signage, etc. unless approved by Landlord.
- ✓ **LED simulated neon**, Neon creativity, combined with good taste and common sense, are watchwords in designing with neon graphics. Although bare tube neon may be acceptable as a graphic design element (when used in moderation) it generally is not favored as a graphic tool. Excessive use of neon or any neon within ten feet of the storefront lease line or on the storefront is restricted by the Lease agreement. Proposed neon details must be submitted with the Construction Documents for Landlord's review and approval.



✓ ACCEPTABLE



✘ PROHIBITED
ARCHITECTURAL DESIGN CRITERIA

2.0 ARCHITECTURAL DESIGN CRITERIA

STOREFRONT DECALS

- ❑ **Decals** in addition to the primary identification sign graphics on the storefront glass doors are permissible. Subject to Landlord approval these may not be illuminated and must adhere to:
 - **Install on second surface, three to four inches (3"-4" in.) max. letter height, thirty six to forty two inch (36"-42" in.) AAF max.**
 - **Charge card decals** shall not be affixed to any part of the storefront, nor shall any charge card identification be immediately visible from the public space.



2.0 ARCHITECTURAL DESIGN CRITERIA

STOREFRONT ELEVATION

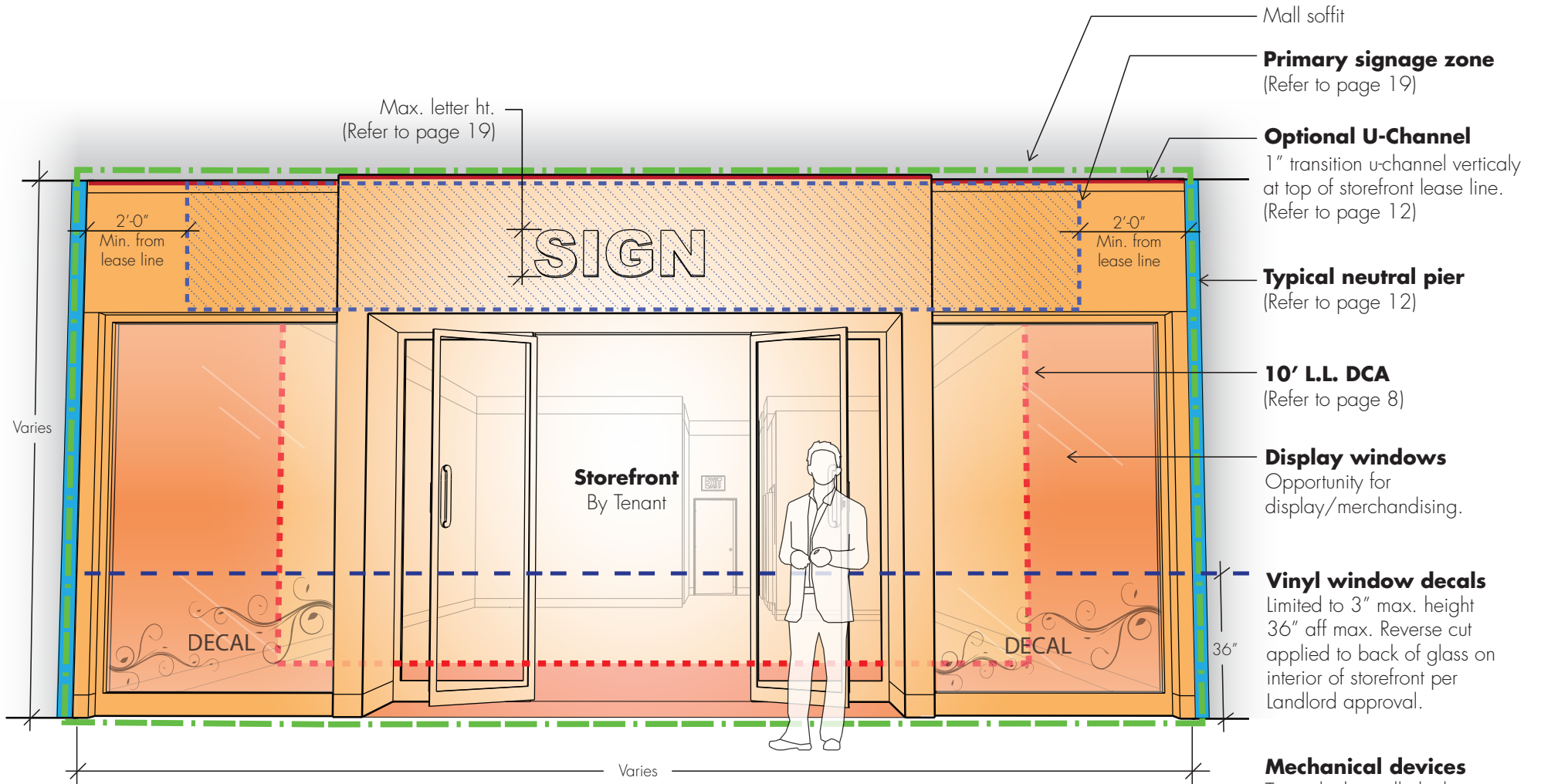

TYPICAL ELEVATION

SCALE: NTS (TENANT SPACES WILL VARY STOREFRONT HIGHTS REFER TO PAGES 31, 46, 47, & 48)

2.0 ARCHITECTURAL DESIGN CRITERIA

STOREFRONT- DIGITAL BRANDING

As referenced in the Design Philosophy section of this criteria, connecting people to your brand through the brick-and-mortar experience is more important than ever. Digital branding (collectively - images, lifestyle graphics, distinctive colors, etc.) is one feature of your storefront design that may help customers discover and connect to your overall brand.

Digital branding in the past had its pitfalls, such as light trespass on to the common mall and other tenants, brightness limitations, flashing or other movement issues. New technologies have addressed many of those previous shortcomings but also create new challenges when being utilized within the mall environment.

The following criteria was created to allow tenants reasonable flexibility and creativity when using digital branding as part of their store design while being respectful of your neighbors and overall mall environment.

❑ Digital Branding Types:

- **Architectural:** Digital LED panels or “Bricks” built right into the storefront architecture and face.
 - **Show window:** LED panels or translucent screens within the Design Control zone at the show windows.
 - **Interior:** LED panels or integrated digital within the store interior that can be seen from the mall common area (around columns, backwalls, at product displays).
- ❑ **Storefront Design Integration: All digital branding must be integrated into a well thought out, interesting, overall storefront design. No freestanding displays. No after thoughts.**
- Such signage shall be installed in accordance with Tenant’s working drawings and specifications and approved by Landlord.
 - The back of unit/display must be finished and integrated into the store design.
 - All cords, fans, frames, transformers, outlets, and mounting attachments must be concealed.

- ❑ **Location:** May be located on/at tenant storefront, Design Control Area, or interior of space.
- ❑ **Audio:** Audio component of the LCD screens is not permitted.
- ❑ **Content: Lifestyle graphics only.** No sales advertising or equivalent content. All content is subject to the decency standards in the lease. All images, content, and formatting are subject to Landlord review and approval prior to displaying.
- ❑ **Light and Color Control:** Newer digital technology allows for quicker and easier adjustments to light display output.
 - Minimize light or color trespass into the common area or adjacent Tenant space...respect your neighbors and the mall environment.
 - Control the light and color intensity electronically or relocate the signage further from the storefront. **All digital branding must be dimmable.**
- ❑ **Movement: Images at/on the storefront must be static. Digital Branding behind the storefront glass (minimum 3-4 ft) may have slow motion. No flashing, flickering or rapid movement of any digital content.**
- ❑ **Landlord approval:** will be granted based on creative design integration. Landlord reserves the right to reject any digital branding or signage in the design review process if not appropriate.
- ❑ **Emergency – Power Off:** The tenant must provide an emergency – power off (physically) and take full responsibility for connectivity and bandwidth requirements. The tenant is responsible for any type of cyber security risk to ensure their content is protected from the outside.

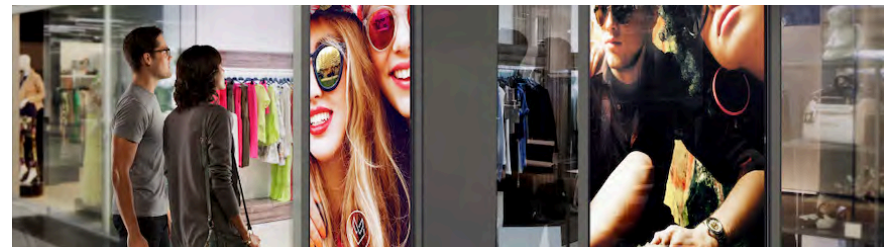

2.0 ARCHITECTURAL DESIGN CRITERIA

STOREFRONT- DIGITAL BRANDING

- ❑ **Size & Area Percentages at Storefront:** Size of Digital Display shall be proportional to storefront square footage and subject to Landlord review and approval.
- The following calculations are examples based on several typical/general storefront sizes and to be used as a guide when determining the overall amount of digital branding proportional to the overall storefront square footage.

■ **12' H x 30' W = 360 SQFT = up to 10% or 36 SQFT.**
Digital Signage not to exceed 6' linear – horizontal,
unless otherwise approved by Landlord.

■ **12' H x 50' W = 600 SQFT = up to 10% or 60 SQFT.**
Digital Signage not to exceed 6-8' linear – horizontal,
unless otherwise approved by Landlord.

■ **12' H x 75' W = 900 SQFT = up to 10% or 90 SQFT.**
Digital Signage not to exceed 8' linear – horizontal,
unless otherwise approved by Landlord.

■ 10% of storefront digital 12' H x 30' W = 36'-0" SQ. FT.

■ 10% of storefront digital 12' H x 50' W = 60'-0" SQ. FT.

■ 10% of storefront digital 12' H x 75' W = 90'-0" SQ. FT.

NOTE:
Digital Media not to extend past storefront
floor base, no media to touch floor.

Example Configuration 1

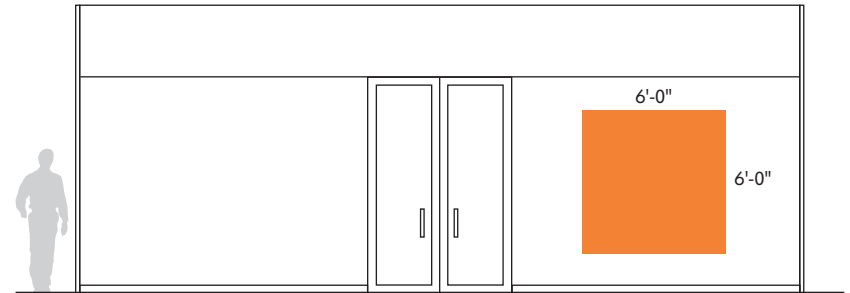

Example Configuration 2

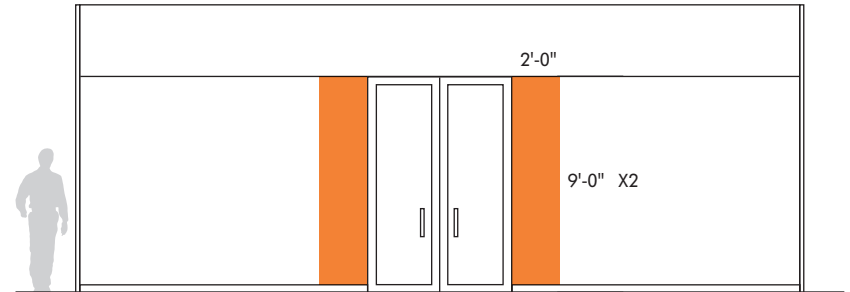

Example Configuration 3



10% of Storefront digital = 36'-0" SQ. FT.

12'-0"H x 30'-0"W = 360'-0" SQ. FT.

2.0 ARCHITECTURAL DESIGN CRITERIA

STOREFRONT- DIGITAL BRANDING

Example Configuration 1

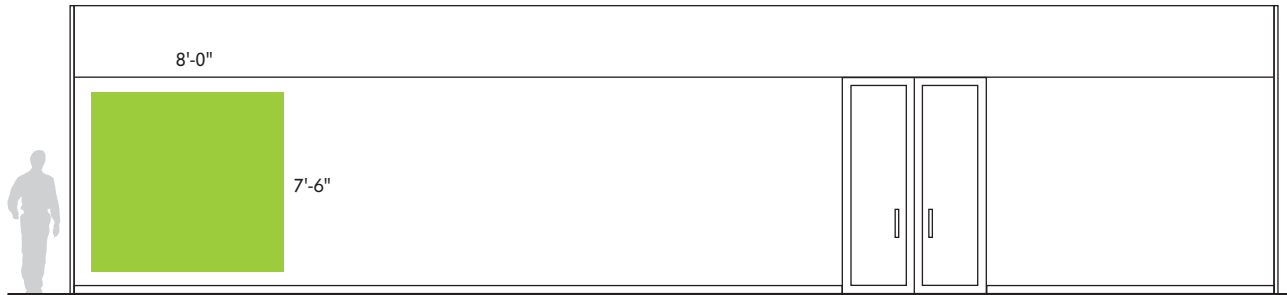

Example Configuration 2

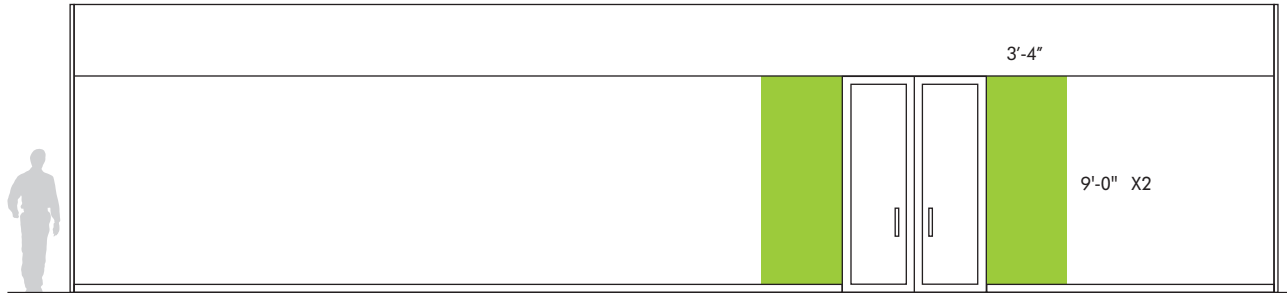

Example Configuration 3

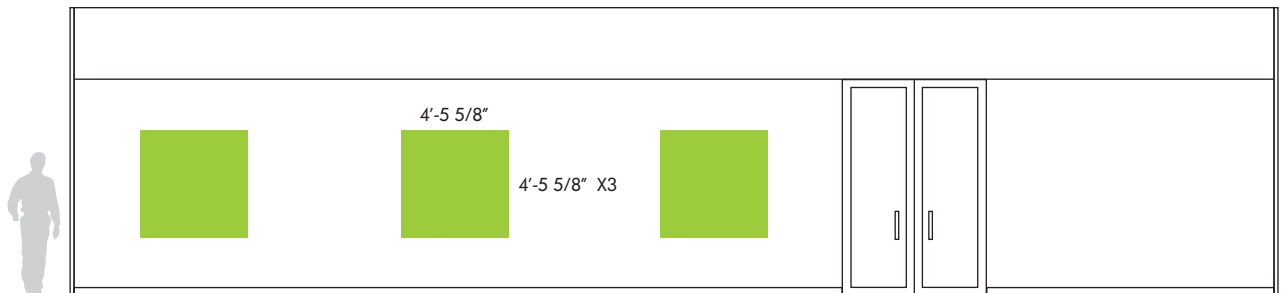

10% of Storefront digital = 60'-0" SQ. FT.

12'-0"H x 50'-0"W = 600'-0" SQ. FT.

2.0 ARCHITECTURAL DESIGN CRITERIA

STOREFRONT- DIGITAL BRANDING

Example Configuration 1

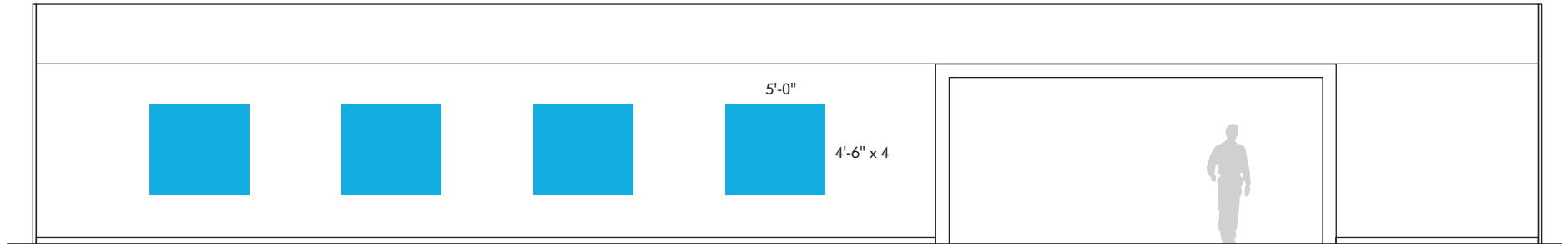

Example Configuration 2

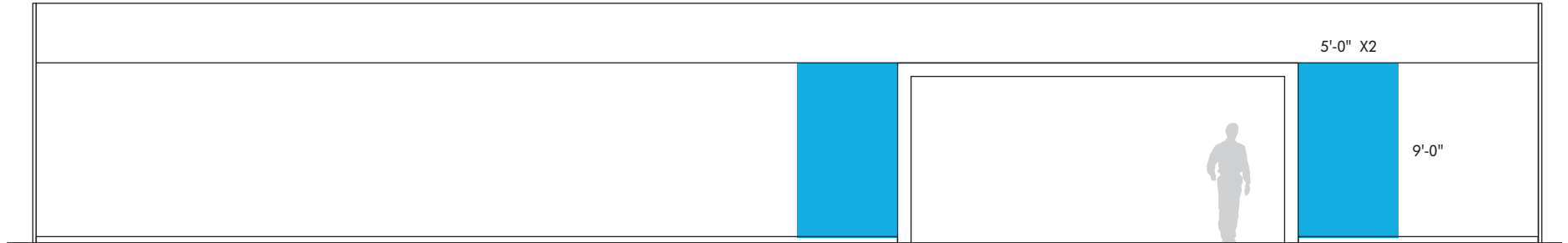

Example Configuration 3

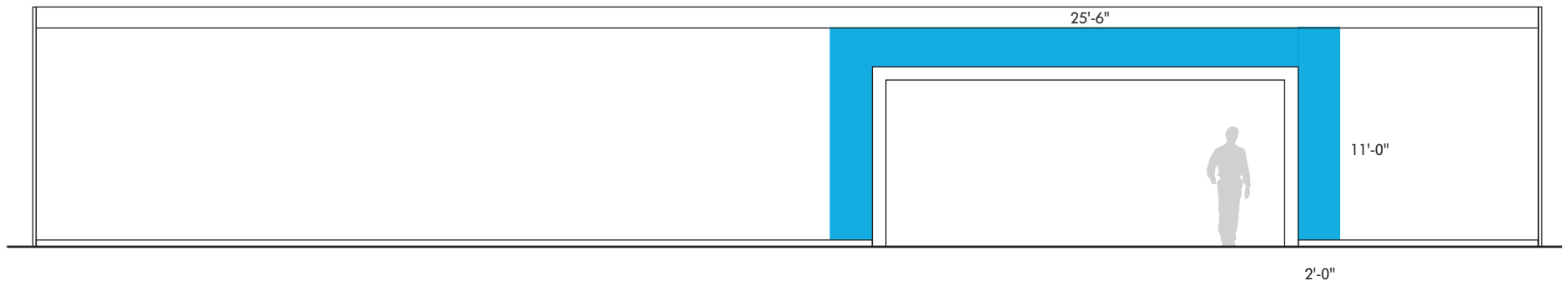

10% of Storefront digital = 90'-0" SQ. FT.

12'-0"H x 75'-0"W = 900'-0" SQ. FT.

2.0 ARCHITECTURAL DESIGN CRITERIA

DIGITAL BRANDING EXAMPLES



Digital Integrated into Storefront Display



Digital Pattern Behind Glass



Translucent Digital Behind Glass



Digital Surrounding Entrance



Digital Display



Digital Integrated into Storefront



Digital Flanking Entrance



Clean Digital Design Integration

2.0 ARCHITECTURAL DESIGN CRITERIA

CEILING TREATMENTS

Just as floor treatments should reflect the fixturing and merchandise layout, so too should the ceiling accentuate the merchandise presentation and Tenant brand.

- ❑ **Open Ceilings:** May be permitted on the first level, if part of the Tenant's brand and subject Landlord review and approval required. All conduits and wiring must be neatly bundled and aligned. Subject to not compromise or impede mall systems (smoke evac, return air, etc.) Review with consultant first.
 - **All upper level stores in spaces in 201 thru 299 must have a ceiling installed throughout the entire store (including stockroom) to create a return air/smoke exhaust plenum above ceiling. No open ceilings with return air/smoke exhaust transfer ducts are permitted.**
- ❑ **Ceiling Attachment:** Absolutely no attachment of anything to the deck on the upper level or pan on the lower level. Anything that can not be floor supported must be properly supported from red iron above per Landlord's approval and structural specifications.
- ❑ **Articulated Ceilings:** i.e. ceilings of various heights, lighting coves, coffered ceilings, soffits, etc. reinforce the design statement, enhance the merchandise, emphasize or deemphasize areas, and provide drama and focus.
- ❑ **Gypsum board ceilings and soffits are required throughout the sales area and in the storefront display area.**
 - **Acoustical lay-in tile ceiling** is only permitted in back of house non sales areas.
 - Combustible materials of any sort may not be used or stored above the Tenant's ceilings.
 - All diffusers, grilles, tracks, speakers, etc., must be painted to match finish ceiling.
 - Concealed sprinkler heads are required in the storefront display area. **(Refer to MEP and FP criteria)**

- ❑ **Ceiling Heights:** Tenant is responsible for field verification of the existing conditions. In some cases, existing utilities may be relocated by Tenant at Tenant's expense. Written approval from Landlord is required before proceeding with such work. **(Refer to pages 31, 46, 47, & 48)**
- ❑ **Metal Suspension Systems:** Metal suspension systems shall be used for all ceilings and shall be secured to Landlord's structural framing only. **No connections to Landlord's deck will be permitted.**
- ❑ **Hanging Marketing Displays:** Tenant hanging marketing displays must provide a recessed track or equivalent discreet hanging method. Hanging grids or other surface mounted hanging methods are prohibited.
- ❑ **Access Panels:** Provide access panels to permit servicing of all Tenant and Landlord equipment located above the ceiling. **Access panels in hard surface ceilings must be a flush panel door with a tape in drywall bead flange.** Access panels should be installed on vertical ceiling soffits or located as inconspicuously as possible.



POSSIBLE CEILINGS (Subject to Landlord review and approval)

- ✓ Tin, aluminum, and other metals
- ✓ Wood slats
- ✓ Panels
- ✓ Open grid patterns
- ✓ Trompe l'oeil painting (faux clouds, windows, etc)
- ✓ 2x2 tegular acoustical lay-in ceiling

2.0 ARCHITECTURAL DESIGN CRITERIA

CEILING HEIGHTS

❑ **First to Second Level:**

- Allowable ceiling height: +/- 11'-6"
- Clear height: +/- 11'-6"
- First floor to second floor +/- 17'-6"
- Storefront Height: 11'-6"

❑ **Second Level to Roof:**

- Allowable ceiling height: +/- 11'-6"
- Clear height: +/- 11'-6"
- Second floor to roof: +/- 19'-0"-20'-0"
- Storefront Height: 13'-6"

❑ **In 2014 Cherry Creek Mall was renovated and raised the mall bulkheads on level 2, which resulted in higher thirteen foot six inch (13'-6") storefronts for Tenants. (Storefront heights were eleven foot six inches (11'-6"), now they are thirteen foot six inches (13'-6") as a result of the higher bulkheads, all level 2 Tenants must utilize the taller storefront height.**

❑ **Both new Tenants and existing Tenants that are remodeling (including limited and full remodels) are required to expand their storefront finishes up to the new thirteen foot six inch (13'-6") height.**

❑ **The storefront change does not affect the store interior "clear" ceiling heights.**

2.0 ARCHITECTURAL DESIGN CRITERIA

LIGHTING

"Light is the magical ingredient that makes or breaks a space."

Interior designer-Benjamin Noriega-Ortiz

- ❑ **Lighting shouldn't be an afterthought...** it is an essential part of your store design and should match your overall brand aesthetic and product offerings. The right lighting design can attract customers to your store, direct them through your space, create an overall ambiance, highlight your brand and products, evoke feelings, etc, which in turn may positively impact how people shop and may bolster your bottom line.
- ❑ **Take energy, cost efficiency, and long-term maintenance into account.** Remember lighting is a significant portion of your stores electrical use (+/- 40%) and that the lighting you install won't take care of itself.



- ❑ **Ambient Lighting:** The goal in ambient lighting design is to develop a general light level consistent with the merchandise or service and allows the customer to distinguish the features, colors, and other attributes of the displayed merchandise. In addition to ambient lighting, Tenants should incorporate a mix of the following to further enhance the overall brand experience:
 - **Accent lighting** performs a multi faceted role in retail design. It can provide focus, orientation, and dramatic impact to the merchandise statement, highlight key displays, enhance the sales atmosphere and provide complimentary illumination to the presentation.
 - **Color Filters:** The use of color filters may be incorporated with these light fixtures to add dramatic effects to merchandise displays. Conventional accent lighting using standard incandescent lamps is not recommended due to its inferior color rendering and focusing properties compared to light sources mentioned above.
 - **Task lighting** is used for tasks in which detail work rather than general illumination is required. There are many methods for employing task lighting but typically, recessed lighting, or table lamps are used. Task lighting can be effective and beneficial, and should be considered for use at the cash/wrap counter, jewelry demonstration, or examination areas, and so forth.



2.0 ARCHITECTURAL DESIGN CRITERIA

LIGHTING-CONTINUED

- ❑ **Lighting Fixtures and Bulbs:** There are numerous types of high quality commercial grade fixtures and bulbs to consider. You will need multiple sources of light in your retail store to create atmosphere, contrast and draw attention to your products... show off your products in the best light by:
 - **Selecting Fixtures:** Vintage fixtures, chandeliers, sconce or dome lighting to create a more intimate feel, recess, track lighting, pendant, or suspended fixtures to help create more of a refined atmosphere.
 - **Lighting in the Design Control Area shall be recessed or concealed behind a soffit** unless otherwise approved by landlord. Lighting outside the storefront display area may be surface mounted.
 - **Lighting shall not spill outside premises** and no direct glare shall be visible to public view.
 - **Fixtures** shall be two feet by two feet (2'-0" x 2'-0" ft.) direct/indirect type with perforated center basket diffusers.
 - **Bare lamp fixtures** such as LED, fluorescent, or incandescent fixtures may not be used except in stockrooms or areas inaccessible to customers.

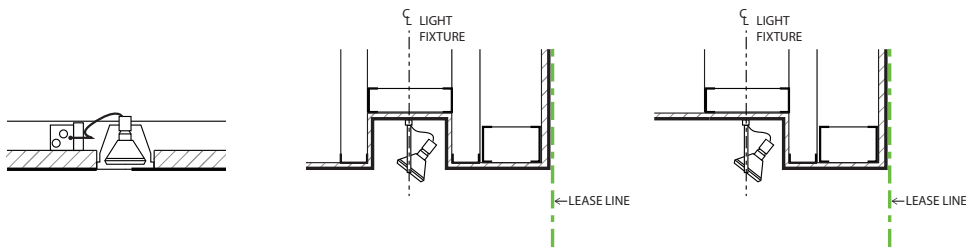

CAN LIGHT FIXTURE

TRACK LIGHT FIXTURE

SOFFIT CONDITION

TYPICAL RECESSED LIGHT FIXTURES

SCALE: NTS

HEALTHY LIGHTING FOR TENANT BUILD-OUTS

- ❑ **Please consider incorporating in your lighting design** the following specifications, which follow WELL Building Standard® and other research-based guidelines.
 - **Ambient lighting** at 200 lux average, Ambient daylight dimming sensors where applicable.
 - **Shielding at the following angles, based on luminance:**
 - 5800 foot-lamberts, including reflected sources: no shielding required.
 - 5800 to 14,500 foot-lamberts: 15°, 14,500 to 145,000 foot-lamberts: 20°, 145,000 foot-lamberts and above: 30°
 - **Controllable task lighting** that provides 300 to 500 lux
 - **Conference room lighting** at 500 lux
 - **The following Light Reflective Values (LRV):**
 - Walls: .7 maximum, Ceilings: .7 -.8, Floor: .2-.4, Furniture: .5
 - **Color Rendering Index (CRI) Ra of at least 80 and CRI R9 of at least 50.**
 - **Circadian Correct Lighting at least 4 hours of the workday:**
 - At least 250 equivalent melanopic lux is present within at least 75% of workstations on the vertical plane facing forward 4 feet above the finished floor (to simulate the view of the occupant).
 - **Maximize Daylight/Natural Light:** Space and lighting design that maximizes daylighting throughout the space, as well as occupant exposure to natural light.
 - **Controllable window shades** or blinds where applicable, Indirect lighting to prevent glares.

2.0 ARCHITECTURAL DESIGN CRITERIA

FLOORING

- ❑ **Floor treatments** should be designed and specified to reinforce the character of the store concept and image.
- ❑ **Hard Surface Flooring to Lease line:** Regardless of the spatial configuration, a hard surface floor material porcelain or stone is required at the storefront lease line and must extend at least four to five feet (4'-0" to 5'-0" ft.) into the store.
- ❑ **Flooring in Tenant's space** shall be hard surface and durable materials that require minimum maintenance. Wood employed anywhere within the leased premises, must comply with code requirements. **(Refer to Wood Flooring)**
- ❑ **Mall Flooring Infill:** Minor recessed portions of the storefront not at the storefront entry may have the standard common area flooring extended into these areas. This infill material is available to be **purchased from the Landlord.** Tenant must use their own flooring material within the store up to the lease line.
- ❑ **No vinyl or rubber base permitted** in the sales area. Provide a hard surface durable base material.
- ❑ **Expansion joints** in storefront or sales areas must be detailed and illustrated in the construction documents. Seismic or expansion joint materials must be compatible with the storefront and floor finish materials.
- ❑ **Anti-Fracture Membrane floor isolation** is recommended to install an anti fracture membrane at the column lines, transitions between the structural slab and any shrinkage cracks that are evident.
- ❑ **Transitions:** All floor finishes at the storefront lease line shall be the same finish floor elevation to ensure flush and smooth transition to mall flooring and throughout sales area. Provide one eight inch (1/8") max. Schluter strip or equal at flooring changes. Reducer/'T' strips are not permitted.
- ❑ **Waterproofing and Drains:** Install continuous elastomeric waterproof membrane across wet-area floor(s) and four to six inch (4"-6") min. vertically up adjacent walls. Provide floor drains as required by code. Provide waterproofing detail at floor and base noting and demonstrating compliance with required installation and testing per Landlord's construction Criteria.

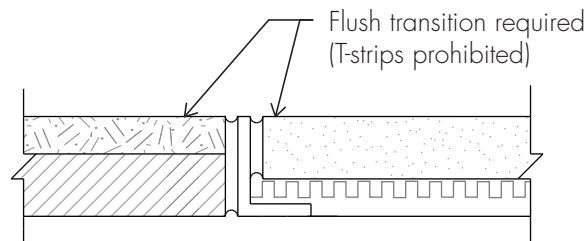
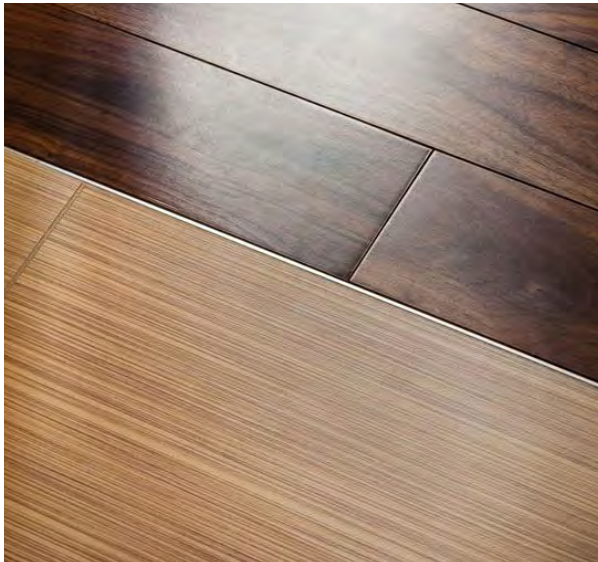

TYPICAL FLUSH TRANSITION
SCALE: NTS (TENANT SPACES WILL VARY)



2.0 ARCHITECTURAL DESIGN CRITERIA

FLOORING-CARPETING



❑ **Carpeting** should be of superior quality. Insets, borders, and walkways can be devised to help identify merchandise categories or areas of special focus by combining different colors, textures, or patterns of carpets.

❑ **Carpet squares** of different sizes and patterns may also be utilized for insets, borders, and walkways.

❑ **Direct glue-down** carpet installation is preferable to carpets installed over padding.



❑ **Flush Transitions:** In all instances it is important that flush transitions be provided between floor treatments to minimize visual distractions and walking hazards. Floor treatment reducer strips can be trip hazards and are not permitted.

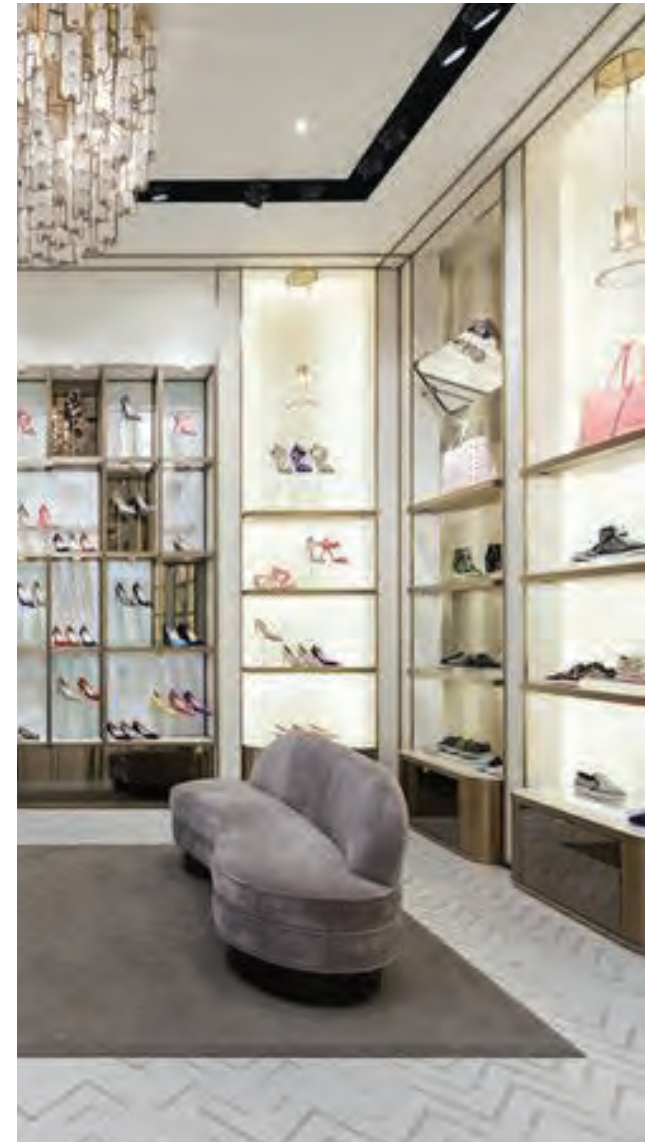

2.0 ARCHITECTURAL DESIGN CRITERIA

FLOORING-WOOD

- ❑ **Solid wood or Engineered wood flooring** with veneers of 2mm thickness or more and commercial grade (10 year warranty) finish are acceptable.



- ❑ **Flush Transitions:** In all instances it is important that flush transitions be provided between floor treatments to minimize visual distractions and walking hazards. Floor treatment reducer strips can be trip hazards and are not permitted.

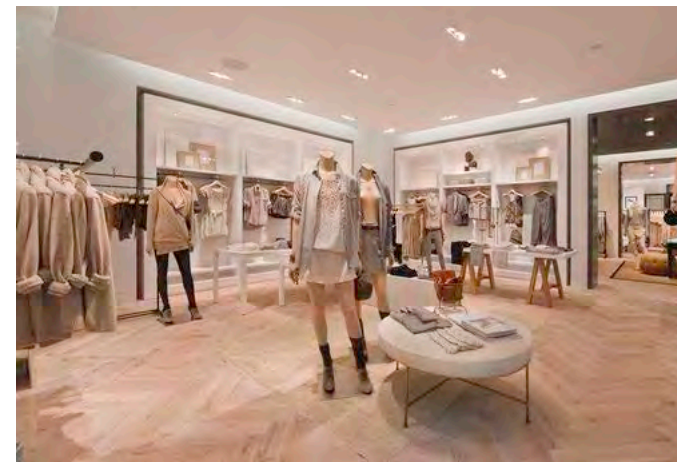

2.0 ARCHITECTURAL DESIGN CRITERIA

FLOORING-POLISHED CONCRETE

- ❑ **Polished Concrete floors** are allowed on a case by case basis, if consistent with Tenant prototype design.



- ❑ **Concrete floors** must be sealed with a high quality, low VOC clear acrylic, epoxy, or urethane sealer, level 2 (minimum) sheen finish.
- ❑ **Submit prototype** design package as part of the approval process.
- ❑ **Pattern/texture** provide score, diamond grind, and/or bead blast pattern.
- ❑ **Finish:** Sealing the surface with clear acrylic, epoxy, or urethane sealer adds varied levels of sheen and depth, and protects the concrete from damage and staining.
- ❑ **Color:** Artistic designs using pigments, paints, and epoxy are acceptable if wear resistant and consistent with prototype.
- ❑ **Flush Transitions:** In all instances it is important that flush transitions be provided between floor treatments to minimize visual distractions and walking hazards. Floor treatment reducer strips can be trip hazards and are not permitted.

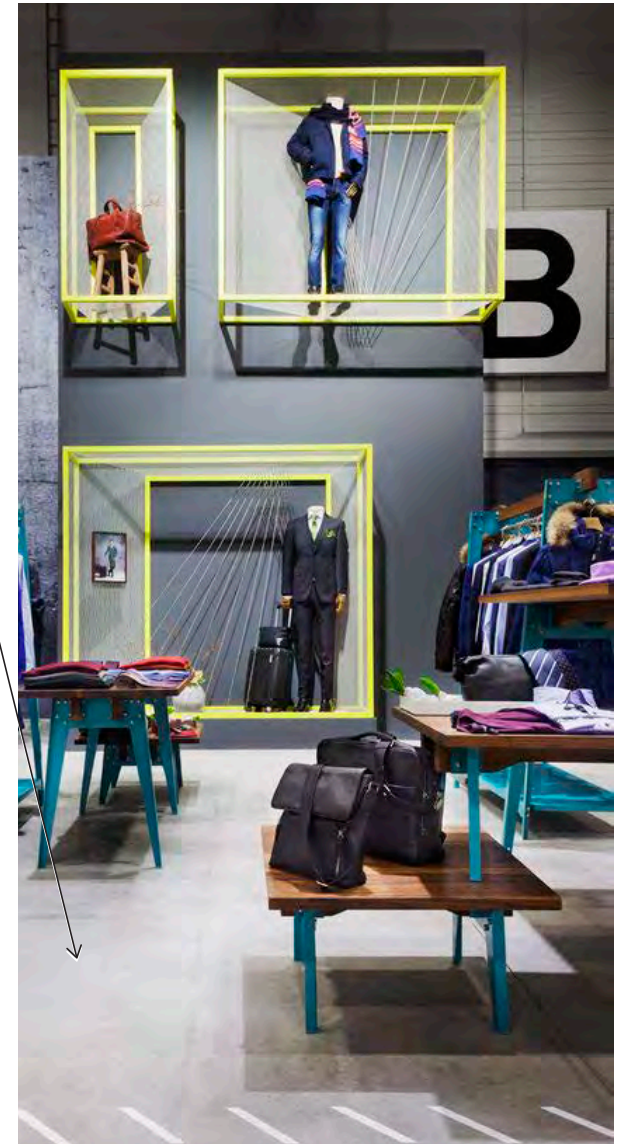

2.0 ARCHITECTURAL DESIGN CRITERIA

FLOORING-TILE

- ❑ **Tile** may be used in diverse applications. Its use is encouraged to introduce light, decorative texture or graphic quality to a storefront.



- ❑ **Porcelain, ceramic, or glass tiles** in glazed or natural finishes may be used as accents and in limited field applications. Patterns used over large areas are expected to have a sophisticated well executed design concept.
- ❑ **Porcelain tiles** are known to be denser and less porous than ceramic tiles. Porcelain tiles are highly resistant against chipping and scratching.
- ❑ **Ceramic tiles** are known to be very versatile in nature and can be used in a wide range of environments without being affected by stains and water.
- ❑ **Grout color** should match the background color of the tile so as not to emphasize a grid pattern.
- ❑ **Mosaic:** Small and intricate mosaic tile patterns may be utilized for detail and accent only.
- ❑ **Flush Transitions:** In all instances it is important that flush transitions be provided between floor treatments to minimize visual distractions and walking hazards. Floor treatment reducer strips can be trip hazards and are not permitted.



2.0 ARCHITECTURAL DESIGN CRITERIA

WALL CONSTRUCTION

- ❑ **Demising Walls:** After Tenant demolition or unless otherwise stated in the lease, Landlord will erect metal stud partitions dividing the Tenant's premises from the adjacent Tenant spaces or common areas at the Tenant's expense. Tenant shall verify Landlord's placement of wall studs prior to space acceptance and advise Landlord in writing of any discrepancies immediately. Failure to notify Landlord of discrepancies shall be regarded as acceptance by the Tenant.
- ❑ **Tenant demising walls** and steel columns shall receive a minimum of one layer of (5/8" in.) fire Type 'X' code gypsum wallboard with taped and spackled joints from floor to underside of structure above on Tenant's side.
- ❑ **Wall Construction:** Tenant's interior partitions shall be constructed of metal stud framing with gypsum board finish on all sides with taped and spackled joints.
 - **Exit/access corridor walls** shall receive one layer of (5/8" in.) fire code Type 'X' gypsum wallboard on both sides from floor to underside of structure above. All joints must be taped and spackled.
 - **Repairs:** Where the premises have been previously occupied and Tenant elects to retain existing walls, the existing walls shall be repaired or improved by Tenant to a condition which will satisfy the Landlord and the fire rating requirements.
- ❑ **Tenant shall provide** and install **non-combustible fire stops** as may be required at separations from the adjacent leased premises and ceiling above mall areas.
- ❑ **Exit/access doors** shall be minimum three feet by seven feet by one and three fourths of an inch (3'-0" x 7'-0" x 1-3/4") one hour fire door or code permitted equivalent and frame with hardware in accordance with governing codes. Hardware must match existing building standards and key ways.
- ❑ **Exit/Access Door Paint and Label:** Exit/access door shall be painted per color specified by Landlord and labeled with store name and number as specified by center management.
- ❑ **Corridor Vestibules: All exit/access doors must be recessed into the Tenant space by means of a vestibule. One layer of half inch (1/2" in.) fire-retardant treated plywood four feet (4'-0" ft.) high with four inch (4" in.) metal corner guards eight feet (8'-0" ft.) high to be installed inside service vestibule recess to match Landlord corridor finish.**
- ❑ **Corridor Vestibules:** Where vestibules are constructed, extend adjacent corridor finishes into the vestibule and provide corner guards as per the Landlord's specifications.
- ❑ **Projections:** Tenant door may not project when fully open into the exit passageway per code.

2.0 ARCHITECTURAL DESIGN CRITERIA

PUBLIC FACILITIES REQUIREMENTS

- ❑ **Stores in excess of six thousand four hundred to nine thousand two hundred square feet (6,400-9,200 SF) leased area.** Are required a minimum of one (1) water closet, one (1) urinal, one (1) lavatory in the mens room and a minimum of two (2) water closets and one (1) lavatory in the womens restroom plus one (1) drinking fountain and one (1) service sink.
- ❑ **In accordance with an agreement with the City of Denver Building Department and the Cherry Creek Shopping Center,** Tenants shall provide employee/public toilet facilities to meet or exceed **the following criteria. Selected toilet facilities must be accessible to the public** without going through a stock area or a food preparation area.
- ❑ **All toilets shall be built in accordance with local handicapped codes.** The required five foot circle may be waived for the single “unisex” toilets. Pursue this issue with applicable authorities.
- ❑ **All populations are fifty percent (50%) men, fifty percent (50%) women.**
- ❑ **A restaurant is defined as a business which sells food to be consumed on the premises.**
- ❑ **Occupancy populations of restaurants** shall be based on fifteen (15) square feet per person in dining areas and two hundred (200) square feet per person in kitchen and associated areas. Toilet room calculations shall include public and employees. Hand washing facilities must be available in the kitchen for employees.
- ❑ **Occupancy populations of “dry-goods” Tenants** shall be based on forty five (45) square feet per person for both upper and lower level spaces.
 - **Population calculations** shall be based on sales area only and will include public and employees.
- **Stores 0–960 square feet sales area:** No toilets required by the City of Denver Building Department. Employee toilet shall be at Landlord’s option.
- **Stores 961–2,400 square feet sales area:** One (1) water closet and one lavatory in a single “unisex” restroom.
- **Stores 2,401–6,400 square feet sales area:** One (1) water closet and one (1) lavatory in each of the two (2) restrooms (men and women), plus one (1) drinking fountain and service sink.
- **Stores in excess of 6,400–9,200 square feet leased area:** A minimum one water closet, one urinal, one lavatory in the men’s room and minimum of two water closets and one lavatory in the women’s restroom, plus one (1) drinking fountain and one (1) service sink. More fixtures may be required in very large stores and retail stores exceeding eleven thousand five hundred (11,500) square feet.
- ❑ **Drinking fountains and service sinks** shall not be installed in toilet rooms.
- ❑ **Where food is consumed indoors,** water stations may be substituted for drinking fountains.
- ❑ **Whenever additional urinals are provided,** one (1) water closet less than the number specified may be provided for each urinal installed, except the number of water closets shall not be reduced to less than two-thirds (2/3) of the minimum specified.

2.0 ARCHITECTURAL DESIGN CRITERIA

INTERIORS-GENERAL

- ❑ **ADA:** All restrooms are to have an ADA complaint marble threshold (or equivalent) to help contain water in the event of a leak.
- ❑ **Rubbish Storage Rooms:** Provide a storage area for rubbish in all food or beverage service operations. All storage area floors above grade level shall have a Landlord approved **waterproof membrane** between Landlord's structural sub-floor and Tenant's finish floor.
- ❑ **Food Preparation and Service Areas:** All food preparation and service area floors above grade level shall have a Landlord approved **waterproof membrane** between the structural sub-floor and Tenant's finish floor. They also must have an adequate number of floor drains.
- ❑ **Health Code:** All finishes shall be in compliance with Health Code Requirements (or approved by local health authority).
- ❑ **Stock Rooms:** Tenants may exit through stock rooms if the stock room is of the same hazard classification as that found in the main retail area.
- ❑ **Stock Room Access:** Not more than fifty percent (50%) of the exit access is through the Stock Room. Stock Room is not subject to locking from egress side. Forty four inch (44" in.) clear aisle defined by full or partial height fixed walls and leads directly to the exit without obstructions.
- ❑ **A clear egress path** of ten feet (10'-0" ft.) is required in the mall concourse area in front of the storefronts. Tables/chairs, signage, and other obstructions must not be located in this space.

COLUMNS

- ❑ **Columns:** The architectural treatment of columns is, an integral element of the store design. If desired, Tenants may even showcase columns, using materials and architectural elements found at the storefront and throughout the store.
 - **Columns** may sometimes be used for focal point display or a single hook garment presentation. **Mirrored columns should not face the common area if within the DCA.**

SOUND & OLFATORY

- ❑ **Sound:** Tenants with above normal sound levels must provide sound isolation in demising walls, floor, ceiling including pipes, conduits, and wires must be designed so that in no event shall Tenant noise emit sounds and/or vibrations which would cause the ambient noise level to rise anywhere in the adjacent spaces.
 - **Speaker location to be twenty feet (20'-0" ft) +/- from storefront. Unless the depth of the storefront requires a closer location. Landlord approval will be required.**
- ❑ **Olfactory "scent marketing"** is subject to Landlord review and approval. Some retailers incorporate ambient scents as part of their retail branding/marketing. In the Mall environment, it must be so subtle that it evokes a reaction without impacting your neighbors or common area.
- ❑ **The Landlord will strictly enforce all Tenant's rights to quiet enjoyment of their leased premises.**

3.0 DETAILS & DIAGRAMS

LOWER LEVEL FLOOR PLAN

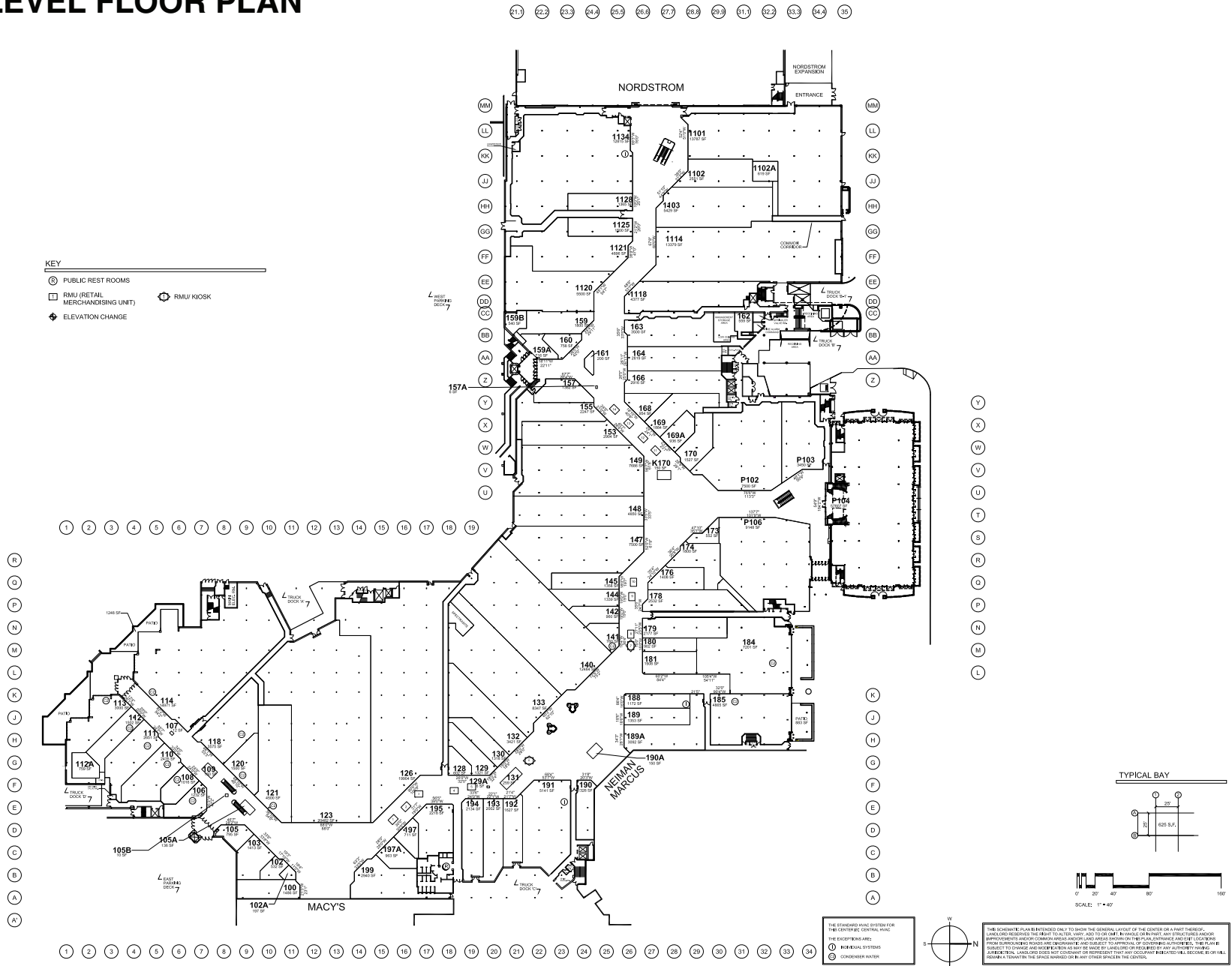

3.0 DETAILS & DIAGRAMS

UPPER LEVEL FLOOR PLAN

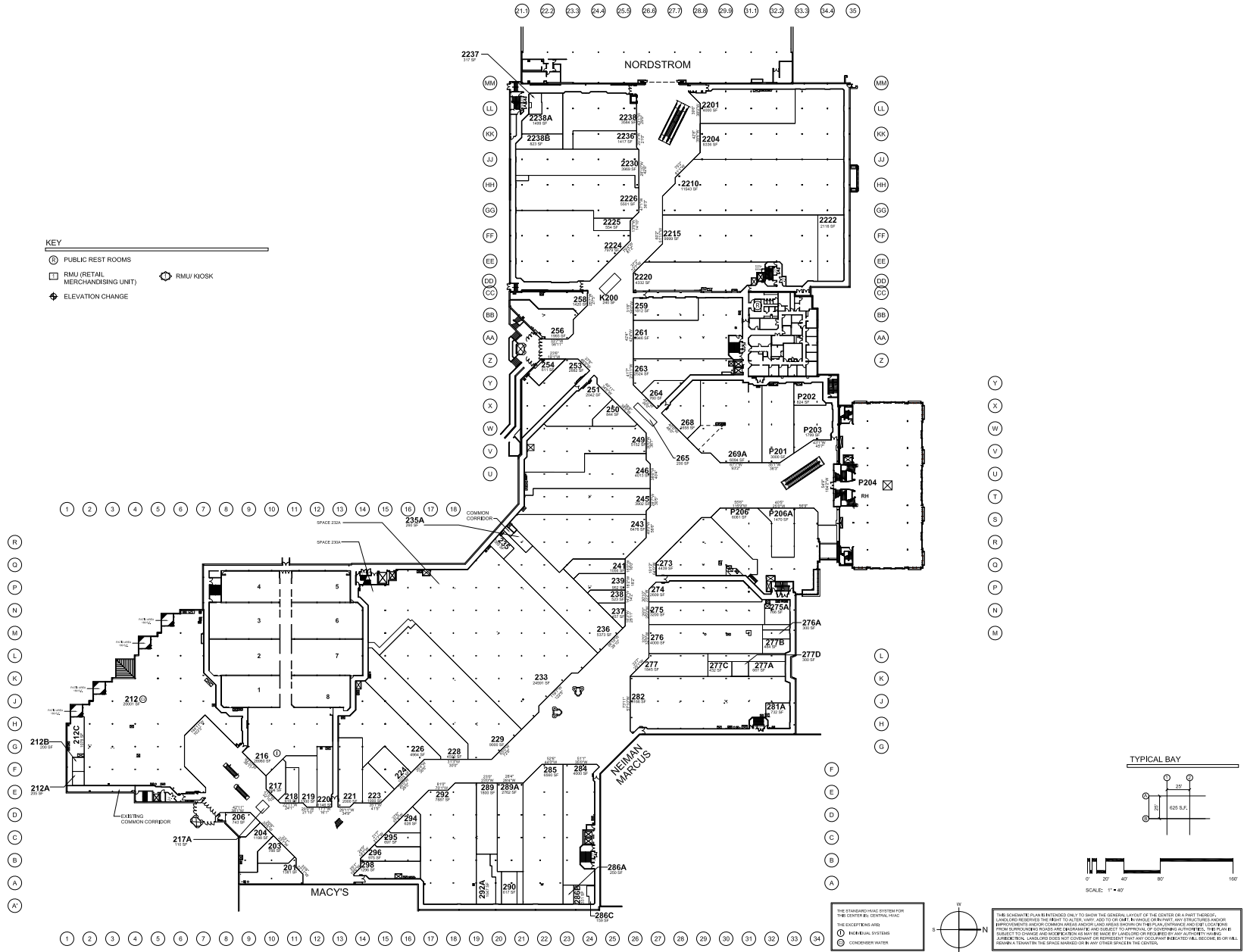

3.0 DETAILS & DIAGRAMS

SITE PLAN

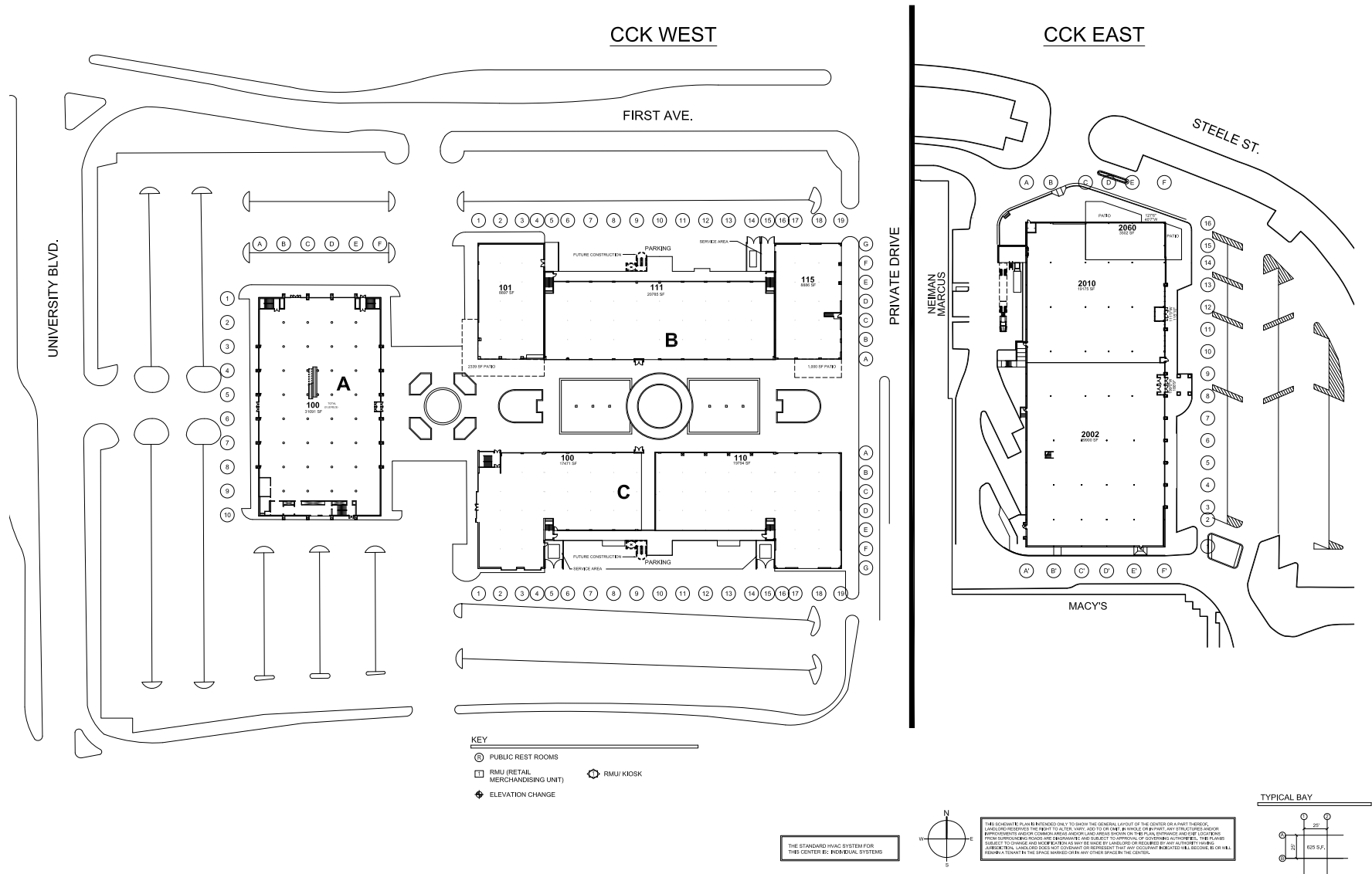

3.0 DETAILS & DIAGRAMS

LOWER LEVEL TYPICAL ELEVATION AND SECTION

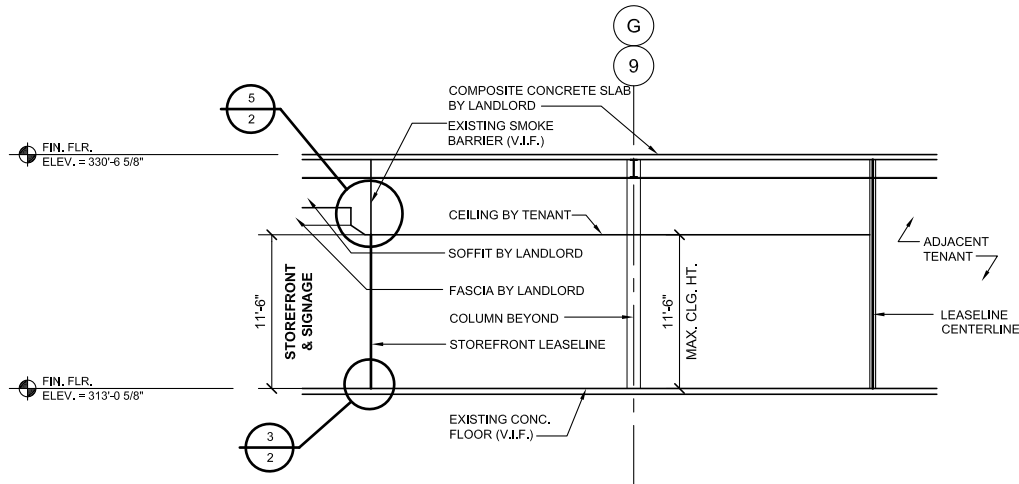

SECTION

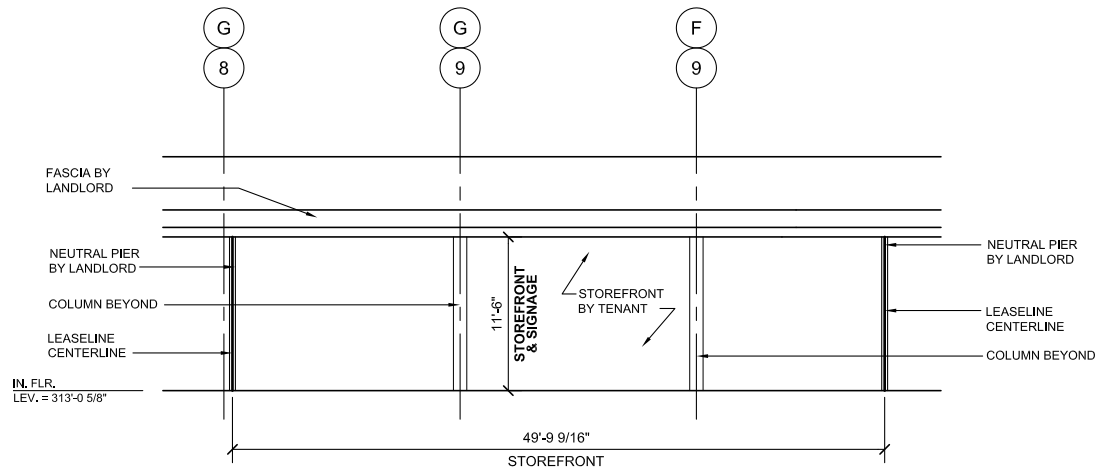

ELEVATION

3.0 DETAILS & DIAGRAMS

UPPER LEVEL TYPICAL ELEVATION AND SECTION

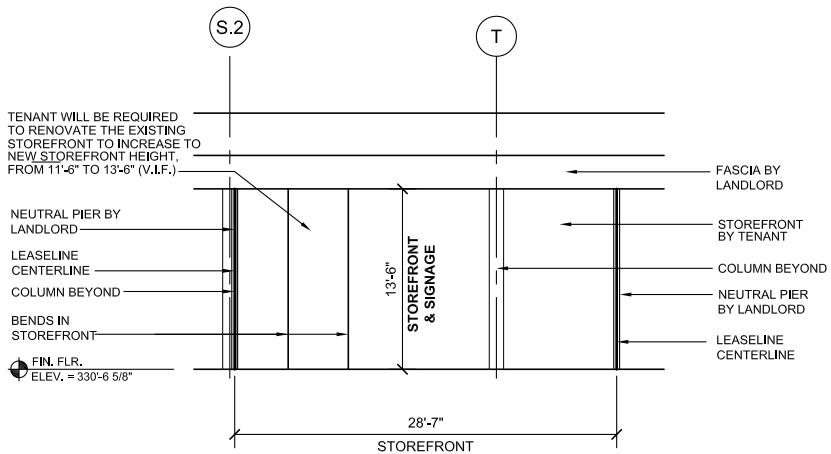
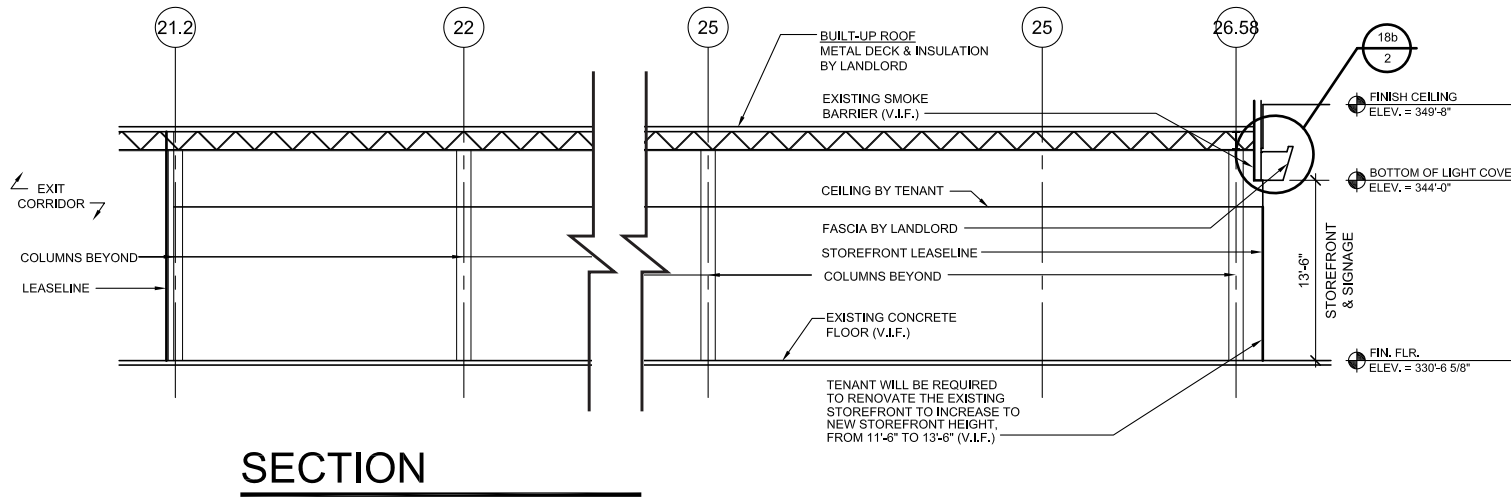

3.0 DETAILS & DIAGRAMS

UPPER LEVEL TYPICAL ELEVATION AND SECTION

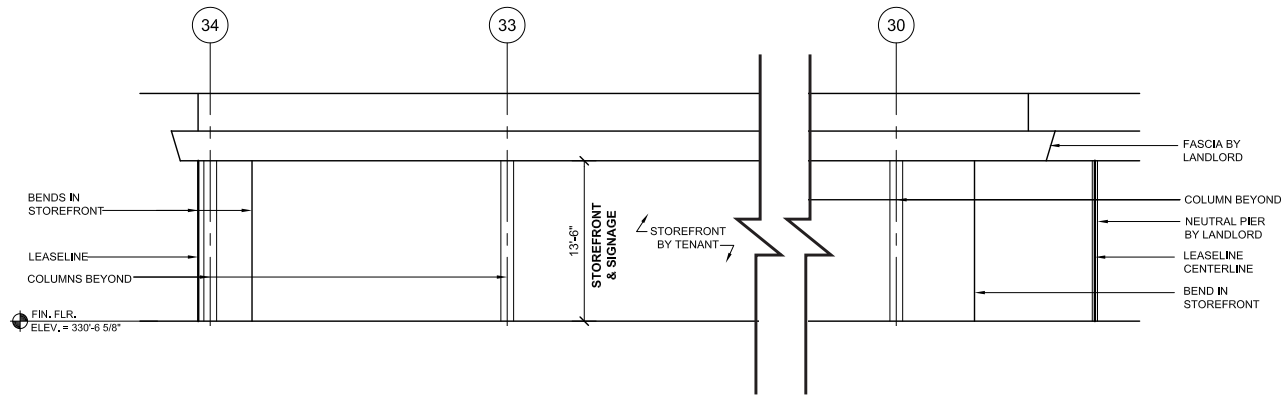

ELEVATION 'A'

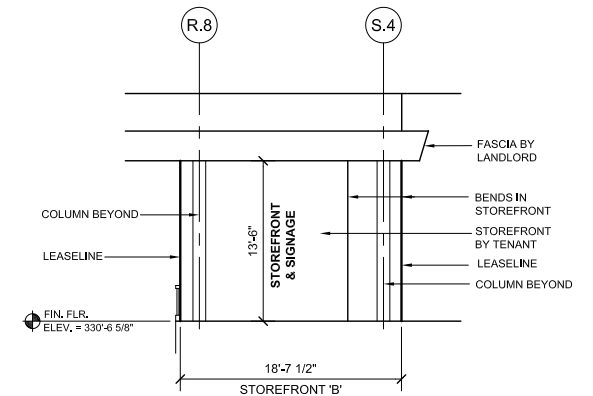

ELEVATION 'B'

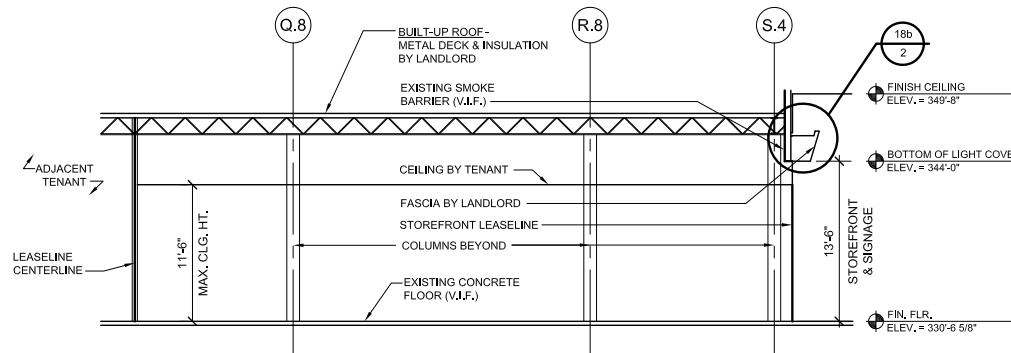

SECTION

3.0 DETAILS & DIAGRAMS

TENANT SERVICE DOOR

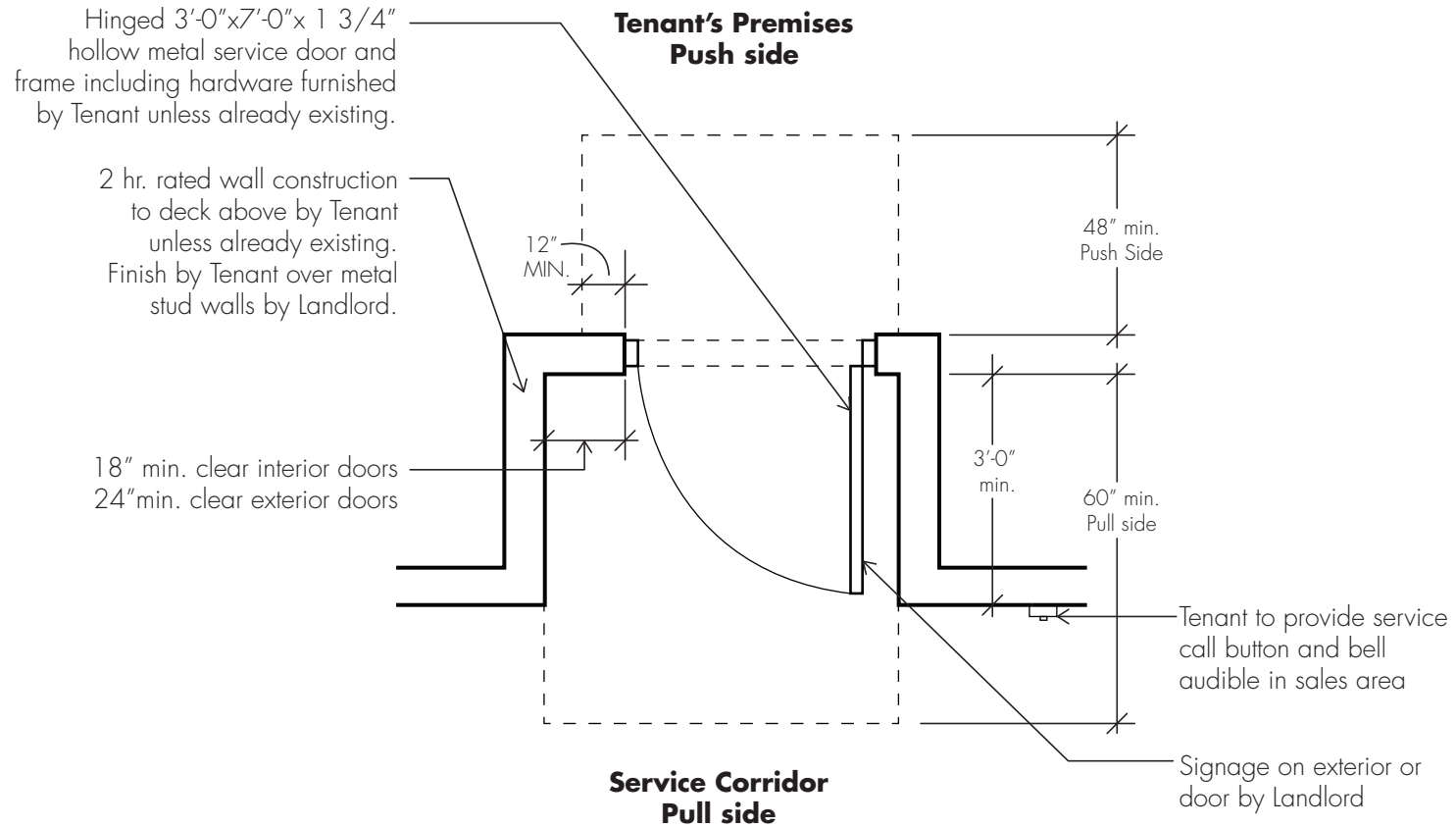

4.0 STORE SECURITY (ADDENDUM)

Security of a tenant's store is an important consideration. Based on the type of store (luxury, jewelry, etc.), location in the mall (interior or exterior entry or storefront), type of storefront (open or glazing), etc., security measures could be different for different tenants.

The following are several store design features that may be included as part of a comprehensive security plan for a tenant space.

GENERAL - INTERIOR & EXTERIOR STOREFRONTS

- ❑ **Glazing:** Laminate glass is common, but tenant may choose glass that is more resistant to strikes.
 - **Consider laminate protection** (School Guard Glass) or adding surface applied film (3M products "Scotchshield") to the back of glass to contain or maintain the glass assembly or similar forced-entry rated features.
 - **Balance Visibility and Opacity:** Consider the balance between visibility and opacity and the amount of free glass as part of a well thought out storefront design.
- ❑ **Stores with both Interior & Exterior Storefronts:** Tenants must "harden" their exterior storefront to prevent access to the interior mall should a break-in occur. This may include less open or free glass; as well as more durable storefront materials such as stone, brick, metals, etc.
- ❑ **Show Windows:** Enclosed show window display areas with doors may consider adding a deadbolt to limit access to the store if a break in occurs in that area.
- ❑ **Lighting:** Consider the balance between providing security and safety lighting and turning off lights after business hours to reduce presence at night (less of a beacon - psychologically).

- ❑ **Security Gates:** One way to secure a storefront entry or display area are security gates. Some of the challenges with gates and gate types are levels of security, installation and construction based on mall and tenant store location.
 - **Pull Across Gates:** Are acceptable for interior mall locations but may require additional pins or strengthening points in the floor and ceiling for increased security/stability.
 - **Roll Down Gates:** Are acceptable for interior/exterior locations. Depending on maximum ceiling height and structural conditions above storefront, Tenants may have issues installing Roll Down Gates.
 - **Conceal All Gates:** All gates must be concealed when not in use and integrated into the storefront design. No surface mounted gates.

GENERAL - STORE SECURITY DESIGN FEATURES

- ❑ **Back Doors:** 4-point lock, pry lock plates are typical.
- ❑ **Rear Egress:** Tenants may want additional concealed security cameras and alarm systems at back doors.
- ❑ **Security Mesh in Walls:** Tenants may install Security Mesh in walls in limited areas and in corridor walls as desired.
- ❑ **Display Cases:** We strongly encourage the use of strengthened display cases for featuring valuable products. Strongly consider using impact resistant glazing materials or laminated glass, reinforced doors, pry resistant locks for your display cases. Also, all display cases should meet the local codes and other standards as needed, "U.L.". Proper installation is critical to ensure the effectiveness of these features.
- ❑ **POS Locations:** Tenants should consider a well lit and visible Point of Sale location as well as reputable POS equipment and operating system. POS location and equipment should be secure, tamper resistant and free of any brochure holders and other items that could hide any devices that could record any store or customer information.

4.0 STORE SECURITY (ADDENDUM)

- ❑ **Queuing:** Consider using Video Analytics applications for queue management. These applications work in conjunction with security cameras and store networks to detect and inform when queues and over occupancy near checkouts appear.
- ❑ **Security Cameras:** Tenants may add additional cameras for more surveillance of additional access points of their store.
 - **Security Cameras, Vision Panels, or "Bubbles" shall not be visible to public view in the design control zone or on patios from the common area. Security cameras in the sales area or near storefronts must be discreet and match adjacent finishes.**
 - **Security cameras must be within the leased premises** and are not permitted on the exterior of the premise (unless approved in writing by the Landlord). However, in cases where Landlord approves exterior cameras or equipment, the cameras or equipment should be positioned as to limit viewing area and shall capture images of the Tenant areas only. In cases where a Tenant may have an approved patio area, all cameras or equipment shall be installed and operated so as to capture only the approved patio area.
 - **All Equipment,** installation methods and locations must be approved by Landlord in writing prior to installation.
- ❑ **Alarm System, Sensors, Monitors:** All systems must be discrete and shall be completely concealed from storefront view. All monitors, sensors (glass, motion, etc.); and control boards shall be out of public view.

All security systems are to be monitored by the Tenant and all elements are to be contained within the Tenant's demised premises.

- ❑ **Security Devices at Customer Entry:** Identify and specify any storefront entry security systems to be used. Door frame mounted or in floor systems are acceptable provided they are incorporated into the Tenant's storefront design and subject to Landlord Approval. No free standing, exposed pedestal or Angel Wing systems are permitted.
- ❑ **Safes:** When Tenants require the use of a safe, please submit weight, location and structural analysis (including path of travel to space) for Landlord's review and approval.
- ❑ **Burglar Bars:** When installing Burglar Bars within ducts and other openings, consult your Design Consultant/Engineer regarding airflow impacts and other code related requirements.

GENERAL - EXTERIOR CONTINUED

- ❑ **BARRIERS:** Physical barriers for exterior stores and restaurants are considerations for additional security measures and may include, bollards, planters, fencing, gates, etc. All elements must be part of a well thought out design and subject to landlord review and approval.
 - **Review all Local Codes** for additional requirements.