

BEVERLY CENTER

Architect's Letter of Certification

Store Name: _____

Center: _____

Space Number: _____

This letter is to serve as certification that the enclosed working drawings for the above referenced space comply with Section _____ of the Lease Data Sheet and Landlord's Construction Criteria as outlined in Exhibit "B" of the Lease Agreement.

Dated: _____

Signed: _____

Title: _____

Address: _____

BEVERLY CENTER

Store Completion Inspection

Store Name: _____

Center: _____ Space Number: _____

The above named store was inspected on ___ / ___ / ___ by this office and is hereby certified to be in compliance with the Construction Documents submitted to and approved by the Landlord dated ___ / ___ / ___.

The following is a list of items either incomplete or inconsistent to those documents:

1. _____
2. _____
3. _____
4. _____
5. _____

(Use Back of form for additional items)

The included list has been forwarded to the General Contractor to remedy same. A copy of this form has also been sent to the Tenant.

Signed: _____

Title: _____

Date: _____

Complete Address: _____

Telephone: _____

Fax Number: _____

BEVERLY CENTER

AC-1,8

Tenant's Air Conditioning Load DATA FORM - AC - 1,8

TENANT _____ STORE# _____

PUBLIC AREA= _____ SQ. FT. WORK AREA= _____ SQ. FT.

COOLING LOAD (BTU/HR) _____

PUBLIC AREA

WORK AREA

Lighting: _____

Equipment: _____

People: _____

Roof: _____

Walls: _____

Misc.: _____

Total: _____ BTU/HR _____ BTU/HR

Cooling CFM _____

Air Changes/Hr. _____

Exhaust Air CFM _____

Make up Air CFM _____

Supplemental Htg. (Optional) _____ KW _____

Prepared by _____

(Engineer and Firm Name)

Telephone _____ Date _____

Note: This form must be completed and returned to Landlord, along with all supporting calculations. Tenant's Drawings will not be processed for approval unless completed forms have been returned.

BEVERLY CENTER

AC-6,7

Tenant's Air Conditioning Load DATA FORM - AC-6,7

TENANT _____ STORE# _____

PUBLIC AREA= _____ SQ. FT. WORK AREA= _____ SQ. FT.

COOLING LOAD (BTU/HR) _____

SALES AREA

STOCK AREA

Lighting: _____

Shoe Case: _____

Equipment: _____

People: _____

Roof: _____

Walls: _____

Misc.: _____

Total: _____

Cooling CFM (20°_t) _____

Air Changes/Hr. _____

Exhaust Air CFM _____

Supplemental Htg. (Optional) _____ KW _____

Prepared by _____

(Engineer and Firm Name)

Telephone _____ Date _____

Note: This form must be completed and returned to Landlord, along with all supporting calculations. Tenant's Drawings will not be processed for approval unless completed forms have been returned.

BEVERLY CENTER

E-1

Tenant's Air Conditioning Load
DATA FORM - E-1

TENANT _____ STORE# _____

FLOOR
AREA= _____ SQ. FT. PRODUCT/SERVICE _____

LOAD TYPE & TOTAL CONNECTED LOAD: _____

Space Lighting (KW) _____

Showcase Lighting (KW) _____

Mall Sign (KW) _____

Receptacles (KW) _____

Appliances (KW or HP) _____

Fan(s) Function & HP _____

Exhaust Fan (HP) _____

Space Heating (KW) _____

Water Heating (KW) _____

Largest Motor (HP or KW) _____

Transformer Size (KW OR KVA) _____

Total Simultaneous Load
(3 hrs. or More – KW) _____

Total Connected Load (KW) _____

Prepared by _____
(Engineer and Firm Name)

Telephone _____ Date _____

Note: This Form must be completed and returned to Landlord, along with all supporting calculations. Tenant's Drawings will not be processed for approval unless completed Forms have been returned.

BEVERLY CENTER

E-2

Tenant's Air Conditioning Load DATA FORM - E-1

TENANT _____ STORE# _____ DATE _____

Refer to Exhibit "C" and applicable Exhibits "D", "E" or "SD" for detail requirements and reimbursements for main service switch to Landlord.

Tenant's Main Service Switch.

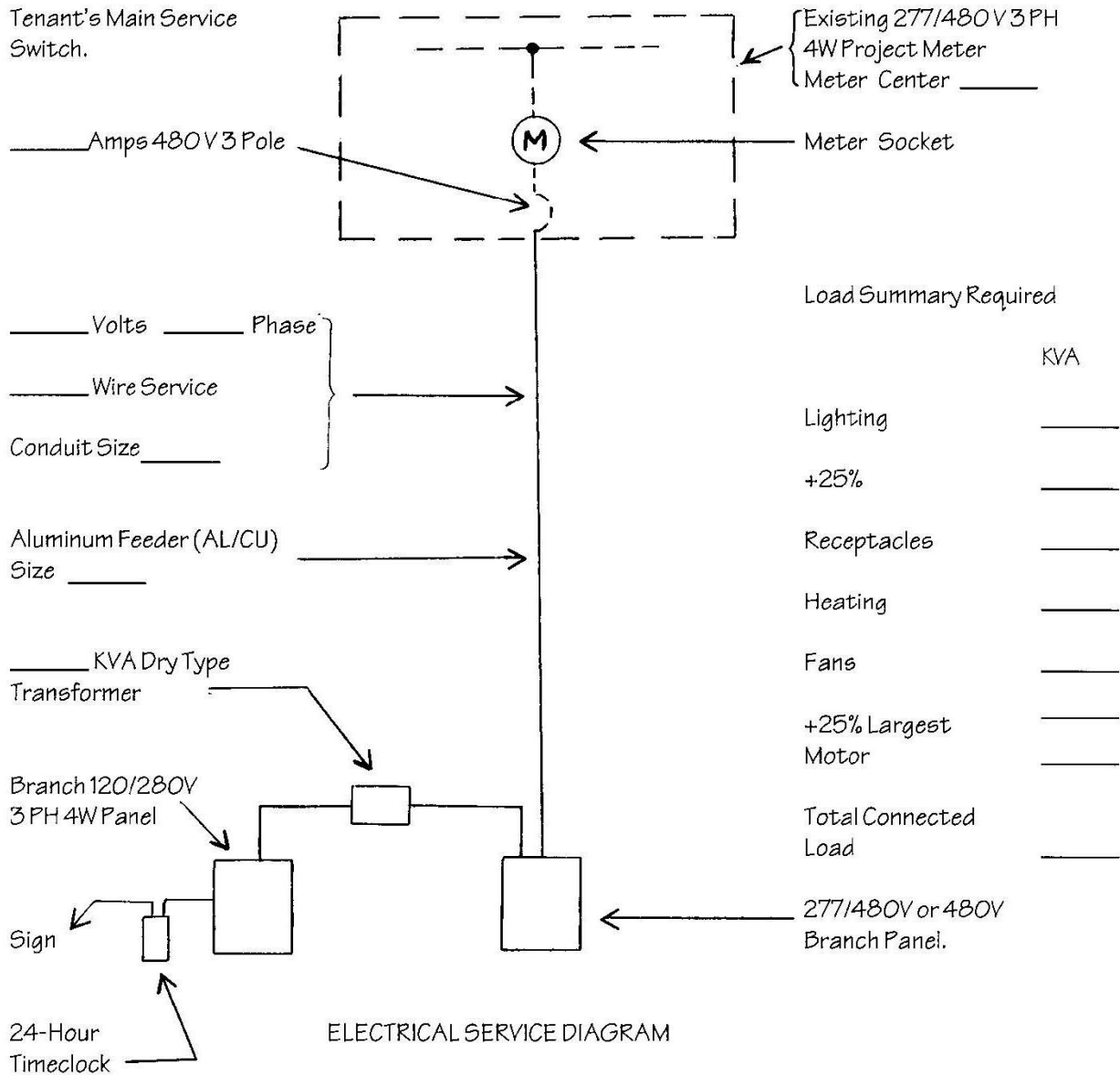

ELECTRICAL SERVICE DIAGRAM

Note: This Form must be completed and returned to Landlord, along with all supporting calculations. Tenant's Drawings will not be processed for approval unless completed Forms have been returned.

BEVERLY CENTER

Pre-Construction Information Form (Continued)

5. Sprinkler Contractor: _____
Superintendent: _____

Address: _____

Office Phone: _____

6. Commencement Date for Construction: _____

7. Estimated Date for Completion: _____

8. Estimated Date for Fixturing: _____

9. Estimated Date for Opening: _____

10. Cost of Construction: _____

11. Evidence of Insurance As Set Forth in
Exhibit "B" Of Lease Agreement. _____

Tenant's Signature: _____ Date: _____

Landlord's Field
Representative: _____ Date: _____